

ON THREE

The Magazine For Apple III Owners and Users



Volume 3 - Number 10

October 1986

\$4.00

* **Apple III
Desktop Publishing**

* **Review ON:
Terminus**

* **Merging
QuickFile**

* **Ram-bo
Pascal**

ON THREE's 512K Memory Upgrade is the Single Most Exciting Enhancement to the Apple /// Ever!

Specially priced at just **\$399***

- Ideal for meeting extra memory needs of applications like /// E-Z Pieces, VisiCalc and Draw ON ///™ or desktop accessory programs.

Just imagine what you can do with:

- **414K in /// E-Z Pieces!**
- **442K in Advanced VisiCalc!**
- **455K in VisiCalc!**
- **456K in AppleWriter 4.0!**
- **456K in Business Basic!**

The ON THREE 512K Memory Upgrade is simple to install by following the directions in the installation manual. Even better, it does not use any of your precious expansion slots and works with all SOS programs. If you ever run out of memory once you have your 512K upgrade in place, you may need a minicomputer!

Another problem the ON THREE 512K Memory Upgrade

can solve is when you are running a hard disk with *Selector* /// or *Catalyst*. Certain programs take up a lot of memory and sometimes there is not enough to go around. And if you think the hard disk is fast, wait till you try the *RAMDisk* that comes free with the 512K upgrade. It'll amaze you with its speed. If you were used to making notes, etc. while your drive was working, you can forget it.

You see, with the limitations of a 256K system, programs like *Selector* /// and *Catalyst*, in conjunction with special purpose utilities like *Desktop Manager* or the *Calendar Pak* will run on only minimal *Selector* or *Catalyst* systems. This means no spooling and a lot of dynamic driver loading. Who needs problems like this? Now you can run, for example, *Draw ON* with *Catalyst* and see your pictures being printed on the printer while you have already started word processing with *AppleWriter* /// or *Word Juggler*.

Read the checklist in the box below to see all the freebies that come with the ON THREE 512K Memory Upgrade.

* The full purchase price is \$449 plus \$10 shipping and handling. (And plus 6% Calif. sales tax for residents.) After installing the ON THREE 512K Memory Upgrade, you can return your old 256K board to us for a \$50 rebate or \$60.00 credit.

If you have an older 128K machine, the cost is a flat \$449 (plus shipping) and no rebate. Installation must be performed by ON THREE or a dealer.

ON THREE also will install any upgrade for you at just \$50. We offer same day turnaround on 256 to 512K upgrades. Call for more information.

The 512K Memory Upgrade is the single most exciting thing to happen to the Apple /// in a long, long time. Using state-of-the-art 256K memory chips, the board is very simple to install and even easier to use. The 512K Memory Upgrade will NOT take up an expansion slot as it is a simple board swap-out. Just keep on using your existing programs—you don't have to change them! VisiCalc, Advanced VisiCalc, /// E-Z Pieces, Apple Writer, Business Basic, Pascal, Catalyst, Selector /// and many other programs will automatically have about 450K of memory to work with.

Look!

At no extra charge, ON THREE's 512K Memory Upgrade includes:

- ✓ Complete 24-page instruction manual.
- ✓ Ultra-fast RAMDisk Drive with demonstration programs.
- ✓ The Upgrade to 512K Utility disk . . . updates all your disks to work with the expanded memory and the Updated version (1.2) of the *System Utilities* program that permits larger SOS DRIVER files.
- ✓ A copy of the *Confidence Memory Program* . . . tests all memory and ensures your 512K Memory board is working correctly.
- ✓ ON THREE's full 90-day warranty.
- and of course, an Apple /// 512K memory board with state-of-the-art 256K memory chips.

ON THREE (805) 644-3514
P.O. Box 3825, Ventura, CA 93006

Calif. residents add 6% sales tax (products only) We accept Visa, Mastercard, American Express†
†3% surcharge on American Express orders

Increase Productivity With a More Powerful 512K Apple ///!

Publisher:
Bob Consorti

Editor:
Val J. Golding

Comptroller:
Joseph Consorti

Logistics:
Janet Schanz

Interior Art:
Virginia Carol

Technical Support:
Terry McNeese

Order Dept.:
(800) 443-8877 (toll free)
(805) 644-3514 (in Calif.)

ON THREE On Line BBS
(805) 644-1055

Typography:
West Coast Typography
Van Nuys, CA

Printing:
Ojai Printing & Publishing
Ojai, CA

ON THREE®—The Reference Source for the Apple /// is published monthly by ON THREE, 447B Market Street, Suite 701, Ventura, CA 93003. (P.O. Box 3825 Ventura, CA 93006.)

For a copy of author guidelines, send a stamped, self-addressed envelope to the above address. Current page rate: \$25 per printed page.

Return postage must accompany all manuscripts, diskettes and drawings submitted if they are to be returned. All manuscripts longer than 500 words or program listings longer than one half page must be accompanied by a diskette if they are to be considered. No responsibility can be assumed for unsolicited materials.

All letters received by ON THREE unless specifically marked to the contrary, will be considered as unconditionally assigned for publication and are subject to ON THREE's right to edit and comment editorially. Your full address will be published only when specifically requested.

Subscription information:
U.S.: \$40 for 12 issues.

For First Class service, remit an extra \$12
Foreign subscription information:
Canada, Mexico, APO, FPO \$20 additional, \$60 total.

So. America, Europe: \$24 additional, \$64 total.
Pac. Islands, Asia, Australia, Mid-east: \$29 additional, \$69 total.

Back Issues:
Available at \$5 each. Please indicate issues desired.
Postage for ON THREE products:
U.S.: listed on enclosed product price sheet.
Canada and Mexico: double listed US prices.
Outside North America: triple listed US prices.

All funds must be remitted in U.S. Dollars drawn on a U.S. bank or funds in your native currency at the current exchange rate drawn on a bank in your country.

Group purchases must have one common mailing address. Please contact ON THREE at the above address for information on current volume pricing and terms.

ON THREE is a registered trademark of ON THREE, Inc. Apple, Apple II, Apple II plus, Apple ///, Apple /// plus, Applesoft, Apple Business Basic, Disk II, Disk ///, UniDisk, Lisa, LisaDraw, Macintosh, MacPaint, MacWrite and ProFile are registered trademarks of Apple Computer, Inc. Micro-Sci and Gameport /// are registered trademarks of Standum Controls, Inc. Selector /// is a registered trademark of Sabre Software, Inc. ON THREE O'Clock, Lazarus ///, Draw On ///, Desktop Manager and ONTIME are registered trademarks of ON THREE, Inc.

Opinions expressed in this magazine are those of individuals authors and staff and not necessarily those of ON THREE.

Entire contents copyright ©1986 by ON THREE. All rights reserved.

SUBSCRIPTION FORM

ON THREE (805) 644-3514
P.O. Box 3825, Ventura, CA 93006

Name _____
Address _____
City _____
State _____ Zip _____ Phone _____

enclosed \$ _____
 M/C Visa AE* NEW RENEWAL
number _____ exp. date _____

Signature _____
*3% surcharge on American Express.

ON THREE

The Magazine For Apple III Owners and Users

/// /// /// /// **Table of Contents** /// /// /// ///

Volume 3, No. 10 October, 1986

FEATURES

- | | | | |
|---|---|---|---|
| New Tricks from an Old Friend:
Apple /// Desktop Publishing 5
Ken Johnson | if you thought your typesetting needs were limited to the mac/laserwriter combination, think again; your faithful /// is equally capable. | Using a RAM Disk with Pascal:
Ram-bo Pascal 21
Dan Martin | whether you're using our 512k ram disk or the one titan supplies it's also available to pascal. |
| Review ON:
Terminus 11
John R. Sollman | terminal communications programs have always presented problems for the apple ///, so try this one on for size. | Tutorial:
Using Catalyst 29
J. Donald Glenn | don't be overwhelmed by management programs like catalyst; they're among the most helpful and productive programs around. |
| Quick File:
Merging Files 19
Phillis Fox | some simple step-by-step instructions that can considerably enhance your use of quickfile | Animation Techniques—Part II:
Graphically Speaking 31
Melvin A. Astrahan, Ph.D. | This month's discourse shows how to move an animated character from one screen position to another. |

DEPARTMENTS

- | | | | |
|--|--|---|--|
| The Editor Dishes it Out:
Apple.Sauce 3
Val J. Golding | awfully honest evaluations of awesome october articles and apple information | De Classifieds 26 | the perfect opportunity to pick up another system without straining your budget |
| The Times They are aChanging:
Block_Write 4
Bob Consorti | new developments regarding the apple /// forever conferences and the long-awaited announcement of spelling manager | True Confessions:
Rantings 27
Richard/Lavona Rann | why the /// community manages to hold together and what you can do to keep things that way |
| ON THREE Price List 9 | check this page out and see if something new shows up. | Call Three: Hot Line 30 | the numbers game where our consultants volunteer to answer your questions |
| Three Questions (and a few answers):
One, Two /// Forum 23 | a perfect and interactive example of ///ers helping ///ers | Apple /// User Groups 30 | another great resource to help you get the most from your apple /// |

ON: The Cover

Our cover story is Desktop Publishing and this month's design reflects the flexibility of the Apple ///-LaserWriter combination.
Title design by Ken Johnson.

Disk of the Month

What is the ultimate time-saver? Why *ON THREE's* Disk of the Month diskettes, of course. Why use your precious time typing in *ON THREE* program listings when they are available on diskette for just \$14.95 (plus \$2 shipping and handling) each?

Better yet, mix and match. Any two or more for \$12.50 each (plus \$4 total shipping and handling). Best bet: the works.

Now is the time to start your collection of these program-filled diskettes from all issues of *ON THREE Magazine*. Bulk and group purchase rates are also available, call (805) 644-3514 to inquire about these super savers.

DOM #1—Extra Disk Space Plus!

This diskette contains all programs from volume I, nos. 1 and 2 of *ON THREE Magazine*. Included: Disk Pak1 with a program to give you four additional blocks of space on your data disks, and Disk Pak2, something you can't do without if you are a Pascal user, a convenient and easy way to list the files on a Pascal directory. Plus graphics and sound demos and more.

DOM #2—Changing Printer Characters

Here is an amazing program you won't want to miss. With it you can print to the Apple Dot Matrix and compatibles such as Imagewriter or ProWriter the same characters that are shown on your video display. Many special fonts, including fancy gothic characters, can enhance your printed output. And, it comes with complete documentation. Also on DOM #2 are the other programs from issue number 3, more graphic demos plus: a program to list files from an Apple II diskette without entering emulation mode.

DOM #3—Redefining a Keyboard

This disk is jam-packed full with programs that appeared in Volume I, No. 4 of *ON THREE*, and includes an easy-to-use program to redefine any or all keys on the Apple /// keyboard. Of particular interest is the ability to reassign the "V" to be the delete key so it can be used on AppleWriter /// and other programs. Also included are all the WPL programs, a disk formatting utility, a graphics sketching tool and still more that we don't have room to list here.

DOM #4—Emulation Patch

Volume II, No. 1 had so many great programs it took two disks, DOM's 4 and 5, to hold them all. DOM 4 has all of the Pascal programs and the *Apple II Emulation Patch*, a way to use any Apple /// Font in emulation. Also included is the Pascal startup program for *Access ///* that lets you autodial. Another fine utility is a Pascal program and UNIT to permit calculations from within the Pascal environment. Demos haven't been forgotten either with *Radiate Graphics Demo* and *Beatles Music Demo*. To top things off, we have included a number of *Draw ON* pictures you can view with the program on DOM #5.

DOM #5—Access Draw ON

Here we find the BASIC startup program to autodial from *Access ///*, and *Ben's SUPER Slot Machine*, along with all of the VisiCalc and WPL programs, and the *Circling Graphics Demo* which will show some of the fantastic images that *Draw ON* can create, plus still more *Draw ON* pictures, along with the *Draw ON ///Picture Demo* which you use to view *Draw ON* pictures.

DOM #6—BASIC Lister Plus!

Straight from the pages of Vol. II, No. 2 is a program which will give you perfectly formatted listings of Business Basic programs, and a Pascal program to guide and assist you in selecting noises for animation and game programs. Both the *Pascal Noisemaker* and the BASIC lister come with full documentation. We've also tossed in still more *Draw ON* pictures and some new fonts, as well. You can use the *Draw ON* viewer from DOM 5 to see them.

DOM #7—Heap Good Stuff

From Vol. ///, Nos. 1 and 2 we present a BASIC heap sort routine and demo, *IMAGEHELPER*, a neat graphics utility to simplify graphic image design, and a menu-driven program to pre-select printer codes and parameters.

DOM #8—Directory Sorting

Here is what you have been waiting for, a complete BASIC and Assembly program to take those old chopped up directories and sort them out in just the order you want. Included also is *Clean.Heads*, a Pascal program which exercises your disk drive at cleaning time and writes a program to remind you when you last cleaned heads, plus a simple utility to read a text file and find out what the contents are without having to write a program on the spot.

DOM #9—Music, Music, Music

Here is a great collection of programs from April through July, 1986. *Music Maker* and *Music Player* let you create and play your own Merry Melodies with alternate sets of DATA statements in BASIC. *Energy Plotter* not only plots energy consumption graphs, but contains techniques to "roll your own." In addition you will find a space game, graphics images and an assembly language subroutine to find maximum and minimum values in an integer array.

DOM #10—Editing Character Sets

A great Pascal program to download and modify or create new fonts, this editor makes child's-play out of designing new text characters to meet your specific needs. Special math signs, foreign alphabets, you can do them all. *Football Pool* is a BASIC program to print out a grid for that office pool. All you do is type in the teams, the scores, and the participants; it does the rest. What? 3-D Video? Yes, indeed, *Stereo Spiral* shows how, using simple Business Basic subroutines. For the more technically inclined, the assembly subroutine *Pixel Inverter* does just that. Also included is *Prompt Procedure*, a collection of Pascal and assembly demos to write to the screen, and a couple of programs in WPL (Word Processing Language) to be used with AppleWriter.

Apple.Sauce

val j. golding

On Top of Things

A current microcomputing trend is the quote unquote Desktop. We have now (for the Apple ///) such programs as *Selector ///*, *Catalyst* and the *Desktop Manager* along with its associated modules. All of these are so-called "background" programs, ones which are ever present in memory but are "transparent" to the user until called upon.

However, shortly after Apple announced the Macintosh, another category of "desktop" program was introduced, that of "Desktop Publishing." This was made possible by another Apple product, the LaserWriter printer, a beastie capable of literally almost anything, in combination with the proper software. In this regard, Apple commenced promoting the Mac/LaserWriter combination as the penultimate tool for creating and printing your own publications and reports without the heretofore necessary intervention of a typographer to produce finished type ready for reproduction.

Yet, in its typical fashion, Apple did nothing to inform users that the LaserWriter could produce equally astonishing results with Apple II and /// computers. And indeed, considering the shortcomings of the software provided with the Mac, a new programming language written specifically for LaserWriter can take even better advantage of the capabilities of the LaserWriter to produce output virtually indistinguishable from that of phototype.

With this thought in mind we point out that this month's cover design, along with the text and page makeup for **Ken Johnson's** lead story *Apple /// Desktop Publishing*, was composed directly on an Apple ///, using the *PostScript* programming language and a LaserWriter. If you are interested in finding new uses for your Apple ///, then you should turn to page 5 and read Ken's intriguing article.

Over the past year we have been literally flooded with letters and phone calls inquiring about terminal communications programs for the Apple ///, which are few and far between. Most users are familiar with the Apple-released *Access ///*, but few appear to be acquainted with *Terminus*, a product of Quark, Inc., most noted for their *Catalyst* program switcher utility.

Since today more and more users are getting "hooked" on modems and telecommunications, prolific **John Sollman** has therefore prepared an in-depth review of Quark's *Terminus* communications program. After reading John's review, there is no question in our mind as to the "way to go." Take the time to read his perceptions, starting on page 11, and see if you concur.

The Apple /// is evolving. Designed and touted by Apple as the ultimate business machine, many small and medium businesses originally purchased ///'s in quantities of two to ten or thereabouts. However, since Apple, in their infinite wisdom decided to discontinue it, a number of businesses have put their systems up for sale in the open market, with

the consequence that many more machines are now in the hands of individual end-users. For the most part, these newer owners are newcomers to computing, far less technically and computer oriented than those who originally purchased Apple ///'s. In this respect, *ON THREE*, as a user-resource magazine for the Apple ///, must be responsive to the needs of the current market. Not only is this reflected in the products we offer, but to an ever-increasing degree in the content of the magazine.

For example, in addition to the articles referenced above, we plan to bring you more material such as this issue's *Using Catalyst* by **Don Glenn**, a tutorial describing how to install and utilize program selector utilities.

Or, hints like **Dan Martin's Ram-bo Pascal**, which demonstrates how Pascal users can take advantage of any of the RAM disks available for the Apple ///, and help in other areas where it truly is possible to "teach an old dog new tricks."

Not to be overlooked is our perennial and popular *One, Two, /// Forum*, a question and answer letters column where users, new and old alike, can get together and swap stories and hints. If you are reading *ON THREE* for the first time, we suggest you "GOTO" page 23 right now and see if you can find answers to some of your problems. If not, the thing to do is to drop a note to the forum so that we, or one of our readers can respond to assist you. Remember, if you want your address and/or phone number published for faster replies, we must have specific authorization in your letter.

Matte Finish

The *ON THREE* welcome mat is out again, this time to **Lynne Denicola** who is going to slide into our seat at the reins of *ON THREE*. We expect that Lynne is going to bring to our beloved magazine what new users need most, the refreshing view of another newcomer to computing and to the Apple ///. As for ourselves, we are off to Shreveport, LA, at the helm of three disk-based magazines, including *Softdisk* for the Apple II. But watch out... we may consider an Apple /// disk-based magazine, not in competition with *ON THREE* (which would be unthinkable), but complementary.

Of the many activities in our life, we have certainly enjoyed most our association with *ON THREE*. That we have learned from our tenure here will be obvious when we tell you that we have ordered an Apple /// as our computer of choice in our new surroundings. Moreover, we do not depart *ON THREE* without regrets, nor do we intend to abandon it altogether. It is our fervent hope that you will see our name on these pages as a continuing contributor.

Often, quotes from the masters are hard to surpass, thus as we once wrote a long time ago in a similar swan song, ... *the moving finger writes, and having writ, moves on.* 

Block Write

bob consorti

It's amazing what a difference a month can make. When I wrote in my last column that *ON THREE* was going to sponsor a series of Apple /// Forever conferences around the country, I had some reservations about the number of people that *ON THREE* and the other vendors could attract at all the different locations. While that was high on my worry list, something else has recently happened to diminish the original plans.

Through recent conversations with other vendors, it is apparent that many of them, despite initial elation over the idea of the /// Forever Conferences, simply can't afford the expense of going to various locations around the country; the /// community just isn't as big as some would like to believe.

About the same time we found that some of the other vendors couldn't manage to attend a number of small conferences, the Chicago-based user group TAU (Third Apple Users) offered to sponsor a single Apple /// Forever Conference in the fall of next year. Since we still would like to help out and get all /// people together, we've decided to throw our full support behind the TAU conference.

With a single large conference, hopefully the small /// vendors who couldn't make it to several smaller conferences will be able to attend one major gathering. For all who have sent in the form naming their favorite Apple /// personalities and programs, they will still be tabulated and the results will both be sent to TAU for evaluation and published in a future issue of *ON THREE* Magazine.

The Good News

While others in the /// world can't, *ON THREE* has decided to continue with at least part of our original plan. *ON THREE* will still go "on the road" during early 1987. We will attend special user group meetings at the locations discussed in the last magazine. As we receive requests from different areas, we may also include them in the road show.

At the meetings we will offer a limited part of the original conference idea. We

will be there to answer questions, show products and generally help out with /// problems. Additionally, the 512K Memory Upgrade installation service, as described last month, will be available.

If the number of requests from a certain area pile up we will contact the local user group and work out times. If a local user group doesn't exist, we will try to get the various users together and suggest they form one.

Anyone who wants to attend the new and bigger Apple /// Forever Conference should contact TAU, c/o Lavona Rann, 1113 Wheaton Oaks Dr., Wheaton IL 60187.

New Stuff

Because this magazine of ours has a good lead time (a few months), I am confident to talk about the latest piece of software we have been writing. Since the completion of the Desktop Manager, one of the things that I have been working on is the spelling checker module for /// E-Z Pieces. As it will have been (by the time you read this) completed, anyone who uses /// E-Z Pieces will no longer need be concerned about mis-spellings in their documents.

The Spelling Manager™ will run as a stand-alone interpreter program, or as a Desktop Manager module. Using it as a Desktop Manager module, you can be in the middle of a /// E-Z Pieces document, select the Spelling Manager from the Desktop Manager menu and immediately spell-check your document.

An 82,000-word plus dictionary comes with the package and a number of user-definable dictionaries can be added. An optional medical and legal dictionary will be available after the initial release. Because of the size and complexity of the program and dictionary, the Spelling Manager requires a large capacity disk drive such as a Micro-Sci A143, UniDisk 3.5 or hard disk with about 500 blocks of free space available.

Tentative pricing on the Spelling Manager is \$79.95 and this includes in the same package both the stand-alone interpreter and the Desktop

Manager versions.

Graphics Manager™

Mel Astrahan, the author of Draw ON ///, Mr. Sandman, and other Apple /// graphics games, has come up with a great new program. Called the Graphics Manager, it too works as either a stand-alone or as a Desktop Manager module. What it does is simply amazing.

Not only does the Graphics Manager allows you to combine text and graphics images on the same sheet of paper, but more importantly, it allows you to place the graphics image anywhere on the printed page that you want, in any size, and in any of four rotations, standard or inverted. If you leave room on a page you've printed with a word processor, you can go to the Graphics Manager, scale the image to whatever size fits the remaining space and position it to print exactly where you want.

When used in combination with the Desktop Manager you can insert a graph or picture in the middle of a letter or other document. You can design a corporate logo with Draw ON /// and easily insert it into the beginning of any document. You can grow or shrink the image or any portion of the image to fit a particular spot on the paper. It can directly load Apple II DOS 3.3 graphics files, ProDos graphics images, //e double hi-res images, and even all of the images created for the PrintShop™ Apple II graphics program.

You can place great looking graphics directly into your letter, newsletter or other document using nothing more than your word processor and the Graphics Manager. Priced at only \$49.95, it's a welcome new addition to the software available for the ///.

Since I've just about filled the room Val left for me, I have to stop writing. Before I go, please remember to send in your Apple /// Forever Conference ballot (from the last issue) to *ON THREE* and please, please do contact TAU to get complete information for attending the first Apple /// Forever Conference. 

Apple /// Desktop Publishing!

ken johnson

Unless you have spent the past year or so in a cave, you must already know that Apple's Macintosh/LaserWriter combination has made tremendous inroads into the realm of traditional typesetting. Desktop Publishing, a term that didn't exist prior to 1985, has become one of the hottest items to hit the microcomputer marketplace since spreadsheets. Apple's advertisements would have you think that the Macintosh is an essential part of this team. While it is certainly the most versatile and best supported front-end input device for the LaserWriter at the present time, it is not the only one and, some say, not even the best.

The Apple LaserWriter was designed to be far more versatile than to be dependent upon a single computer as a front-end input device. For example, the heading of this article, while printed on a LaserWriter, was created on none other than our old friend, the Apple ///. No, you can't hook up your Apple /// to an AppleTalk network and run the same kind of WYSIWYG (What You See Is What You Get) graphics oriented software currently available for the Macintosh, not yet anyway and probably never. What you can do, though, is to write PostScript language programs which can be interpreted by the LaserWriter, then port them directly into the LaserWriter right from your Apple /// using tools you probably already have available to you! And let's face it, Apple /// users, since there's not a whole lot of new software being developed for the /// these days, you've probably gotten used to making do with tools already available to you, right?

PostScript, the language used by the LaserWriter, is rapidly becom-

ing the standard page description language of the typesetting industry. The PostScript interpreter resident within the LaserWriter, or that of any of the other typesetting machines which use it, does not require a sophisticated compiler or specialized input software as an interface. It accepts standard ASCII files as input, files which can be generated from virtually any word processor capable of generating an ASCII text file. Hooking up a LaserWriter to an Apple /// is simple. In addition to the AppleTalk connector, the LaserWriter has a 25 pin RS232 connector, like the one on the back of your Apple ///, and three switch selectable modes of operation in addition to AppleTalk. These additional modes are 1200 and 9600 baud and Diablo 630 emulation. All you need to know is the proper communication protocols to access these modes.

The PostScript language allows you to create some truly incredible effects with text and graphics, difficult to duplicate by other means, and still beyond the direct capabilities of virtually all Macintosh WYSIWYG page composition software currently available. It would take several articles, even books to scratch the surface. What I would like to do here is to present a simple illustrative example of a PostScript program used to generate the headline to this article. For most of you it will probably be your first exposure so I will try and keep it simple. Before we get into the program that was used to create the article heading, though, there are a few things about PostScript that it would be useful to know.

In PostScript, a gray scale value of 1 represents white while a value of 0 represents black. PostScript

defines locations on the page in terms of xy-coordinates expressed in points. A point in this instance is a printing measure equalling 1/72 inch. The lower lefthand corner of the page is defined as coordinates 0,0. Coordinates 72, 720 represent a point 10 inches up and 1 inch to the right relative to the bottom lefthand corner of the page. Coordinates can be expressed as decimal fractions and need not be expressed as integer values. The LaserWriter's 300 dot per inch resolution means that it can plot the position of an individual dot with about .25 point precision. Higher resolution, and cost, PostScript output devices can do better. (More on them later.) The coordinate system origin may be relocated anywhere on the page and rotated to any angle desired. PostScript uses a form of reverse notation known as postfix notation where the command follows the parameter list. Its syntax most closely resembles that of the FORTH programming language. Text to be printed is enclosed in parentheses. A "/" character preceding a word means that the word which immediately follows is an identifier as opposed to a command. The "%" character identifies everything that follows, up the next "newline" or RETURN character, as a comment. Procedures may be defined and used within a PostScript program to perform repetitive steps. With this much information in mind, let's look at the instructions that produced the article heading.

The listing in Figure 1, while by no means presented as a model of optimized PostScript code, should serve as a brief introduction to how this language works. Findfont, scalefont, setfont, moveto, show, def, translate, setgray, for,

```

% Set up the initial font specification
/NewCenturySchlbk-Roman findfont 10 scalefont setfont
% Position and print the introductory line
36 734 moveto (New Tricks from an Old Friend:) show
% Change font specification for byline
/NewCenturySchlbk-Italic findfont 10 scalefont setfont
% Position and print the byline
36 658 moveto (ken johnson) show
% Change font specification for main title line
/NewCenturySchlbk-Bold findfont 24 scalefont setfont
% Define procedure for printing the main title line
/printline
{ 0 0 moveto (Apple /// Desktop Publishing!) show
} def
% Relocate coordinate system origin
46 700 translate
% Execute loop including previously defined procedure
.9 -.1 0 { setgray printline -.5 translate} for
% Fill the title string with white, and trace its outline with fine line
0 0 moveto
(Apple /// Desktop Publishing!) true charpath
gsave 1 setgray fill grestore
.25 setlinewidth
stroke
% Output the page
showpage

```

Figure 1.

setlinewidth, charpath, gsave, fill, grestore, stroke, and showpage are all PostScript commands used within this program example. The command `/NewCenturySchlbk-Roman findfont 10 scalefont setfont` tells the LaserWriter to look up the New Century Schoolbook Roman font within its built-in font dictionary and set it at 10 point size for printing text. New Century Schoolbook happens to be a LaserWriter Plus font. Three different versions of this font are used here; Roman, Italic and Bold. As far as the LaserWriter is concerned, and for all practical purposes, these are three separate and distinct fonts.

The extreme top line and byline of the heading are simply located on the page relative to the standard coordinate system and printed one time. The gradual shading effect of the line which reads "Apple /// Desktop Publishing" was achieved by successively printing darker gray versions of the same

text, stepping up 1/144 inch and to the left 1/72 inch between each version. A procedure called "printline" is defined and used to print the text of the line during each iteration. Each line is printed, then offset slightly and reprinted in successively darker shades of gray. PostScript's "translate" command is used to relocate or "translate" the origin of the coordinate system in these small increments within the "for" loop which is used for iteration of the successively darker gray versions of the line. The upper and lower bounds of the "for" loop are established as .9 (light gray) and 0 (black) and the step increment is -.1. For the final iteration of the line, we do things a bit differently and print an outlined version of the string as a geometric shape filled with white. The text outline is determined with the "true charpath" sequence and filled with white by the "1 setgray fill" sequence. "Gsave" and "grestore"

bracket the "fill" command here to avoid altering the current graphics state. The "showpage" command is what finally tells the Laserwriter to output the finished page.

The example presented here is a fairly simple one. PostScript can also do things such as rotating text and producing very complex graphic images and effects. You may have seen examples in various articles which have begun to appear in a number of magazines. Expect to see much more, both in the form of information about the language and in the form of its output in the printed media. PostScript opens up endless possibilities, creative logo and advertisement design, for example, containing effects difficult, expensive, or even impossible to produce using conventional graphic arts techniques. Best of all, it opens up these possibilities to anyone with access to a word processor or text editor and a willingness to master some of the intricacies of a new programming language. Fortunately, there is help available to you as an Apple /// user to help you get started.

There is already a utility available, Don Lancaster's AppleWriter/LaserWriter Utilities, that works with the PRODOS version of AppleWriter // using WPL to facilitate the generation of and access to PostScript text files from an ordinary word processing environment. This is currently a five disk volume set of WPL and PostScript files. Refer to the feature article in the July 1986 issue of A+ Magazine for further information. Perhaps you read this article and thought that here was another example of the old Apple /// getting left in the dust by its inferior but more prolific little brother. *Wrong!* Since this utility is nothing more than a WPL enhancement to AppleWriter //, *it will work equally as well with AppleWriter /// with just a few minor modifications!* These modifications consist merely

of substituting SOS compatible commands for PRODOS compatible commands within the WPL files, .d1 vs ,d1 for disk drive referencing and "field separator" (CONTROL-\) for "form feed" (CONTROL-L) for clearing the Apple /// console display. This takes a little time since you have to go through each WPL file individually, but is easily done using AppleWriter's find and replace feature. You will also need to remove some control commands that are inserted at the beginning of some of the longer PostScript files. These activate the XON/XOFF protocol of the Apple // Super Serial card and are not necessary when using the Apple /// .RS232 driver. If left in, they will confuse the LaserWriter which will try to interpret them as PostScript commands. I've taken the modifications a step further and set the files up so that volumes 2 through 5 will work from a hard disk or MicroSci A143 directory, but that is optional.

The results that you can achieve with this utility will astound you. Several excellent examples of PostScript programs are included. You can, for example, generate customized form letters in any LaserWriter font with striking PostScript generated graphics at a rate of 8 per minute. The marriage of WPL and PostScript lets you do things not possible with either alone. WPL provides a menu-driven mechanism for loading, altering, and printing PostScript which is nearly transparent to the user. AppleWriter can easily print directly to the LaserWriter, incidentally, using the standard AppleWriter print command through an appropriately configured .RS232 driver. Use System Utilities to configure the .RS232 driver with XON/XOFF protocols (see the Standard Device Driver Manual for instructions). This is necessary with files longer than about 5,000 characters to avoid

overflowing the LaserWriter's limited input memory buffer.

The advantage of printing from AppleWriter is that you have the full power of WPL at your disposal. The disadvantage is that your PostScript files must be error-free. If the LaserWriter encounters an error in PostScript, in most cases it will abort, sending back an error message to the initiator identifying what it found wrong. Since AppleWriter is not designed to receive and display such messages back from a printer, you will never see them. (Solvable through development of a special driver perhaps?) The only way that you would know this happened, other than waiting a long time with no output being generated, would be by observing the amber status light on the front of the LaserWriter. Two rapid flashes repeated once per second several times in succession is a sure clue. This tells you that the LaserWriter has given up on your file and is waiting for another. It will do so for about a minute after which time it will "time out" and revert to an idle status. For this reason, I recommend using Access /// to debug PostScript files prior to using them with AppleWriter, since Access /// will display error messages sent back by the LaserWriter.

Let's look at the setup protocols you need to know for communicating with the LaserWriter from Access ///. Both the LaserWriter and the Apple /// should be turned off as a precaution before connecting the serial cables between them. (Powering down the LaserWriter also has the advantage of clearing information resident in its memory from prior use which could otherwise interfere with what you may want to do.) Connect a serial cable between the serial port of the Apple /// and that of the LaserWriter. (This cable must have a "null modem" configuration, i.e. modem eliminator

crossing lines 2 and 3.) Turn on the Apple /// and boot up a version of Access /// with the .RS232 driver configured. No special driver for the LaserWriter is necessary. To set up the appropriate protocols, press the OpenApple-s key combination from the terminal mode of Access /// to enter the configuration mode and set Access /// up as follows:

ANSI mode
Do not send LF after CR
8 bits per character
Enable XON/XOFF
Full Duplex
9600 baud
No parity

Use the CONTROL-s option to save the settings, if you wish. Place the LaserWriter selector switch at 9600 baud, then turn it on. Once the LaserWriter has completed its startup diagnostics and generated a test print you are ready to go. You can test the hookup by pressing CONTROL-d, CONTROL-t on the Apple /// keyboard once you are in Access /// terminal mode. The LaserWriter should respond with [%% status: idle %%] on the Apple /// screen, indicating that it is ready to go to work. At this point, you have two choices. You can operate in a "batch" mode, transmitting an existing ASCII file to the LaserWriter using the Access /// "Transmit a file" option, or you can enter an "interactive" mode whereby you can type commands in and have them processed by the LaserWriter individually as entered. I suggest the latter method for starters. To do this, type the word "executive", then press RETURN. The LaserWriter will respond on the Apple ///'s screen with a header identifying the version of PostScript currently resident in the machine (Version 38.0 in the case of my LaserWriter Plus) followed by the prompt PS>. Each time that you enter a line of

instruction text and press RETURN, you will get either a PS> prompt alone, meaning that the previous command was valid, or you will get an error message followed by the PS> prompt. Remember, while the LaserWriter may have the outward appearance of an ordinary office copier, you are actually communicating with the most powerful computer that Apple has built to date.

There are a few editing key functions that you should know about when communicating interactively with the LaserWriter. They are as shown in Figure 2. The interactive mode is good for experimenting with PostScript and finding out how the LaserWriter's PostScript interpreter operates. Don't worry about making mistakes. The LaserWriter will let you know when you do, but is quite forgiving in its interactive mode as opposed to its batch mode. Once you have gotten the feel of what's legal and what's not in terms of PostScript commands which the LaserWriter will process, try preparing and transmitting a PostScript ASCII text file.

To prepare the LaserWriter to accept a text file transmission, you need to exit the executive mode and enter the batch mode. Do this by typing CONTROL-d, the end-of-file command. Entering CONTROL-t at this point should cause the LaserWriter to generate the [%% status: idle %%] message again on the Apple /// monitor screen. During file transmission, if the LaserWriter encounters an incorrect statement, it will ignore everything beyond, giving you the appropriate error message. To fully interpret these messages requires access to the publication Inside LaserWriter (not recommended unless you are into LaserWriter software development) or the PostScript Language Reference Manual which contains a fairly extensive section on the

Apple LaserWriter. (See the end of the article for information on where to obtain these references.)

Thus far I have mentioned only the Apple LaserWriter as an output device. It is not the only game in town by any means. There is a growing list of such devices, including two high-end machines from Allied Linotype in the \$30-50,000 range which produce output at up to 2450 dots per inch resolution, all of which use the PostScript language. The Allied Linotronic 100 and Linotronic 300 machines achieve their relatively high resolution by outputting to photographic paper or film which must then be processed. Several 300 dot per inch laser printers are now on the market in addition to the LaserWriter, all of which use a dry toner xerographic copy process. Don't look for much improvement in resolution beyond 300 dots per inch for these low-end devices. It would apparently require a major breakthrough in copier technology to achieve this. Do expect some very competitive pricing within the 300 dot per inch laser printer market and the introduction of several more such machines in future months.

Many service bureaus are springing up all over the country who, for a fee, will process typeset pages from PostScript text files. Some may even rent you time on a LaserWriter or other PostScript output device. Many accept file transmissions via modem. Chances are this is the means that you would have to use for files that you generate with your Apple /// if you do not have access to a PostScript compatible device that you can connect your Apple /// to directly as described in this article. Most service bureaus accept Macintosh disks with certain application files which generate PostScript compatible output. Macintosh applications, for the most part, output to PostScript devices via special drivers which automatically

Interactive LaserWriter commands:

Backspace (CONTROL-H) backs up and erases one character
Delete same as backspace
CONTROL-U erases the current line
CONTROL-R erases the current line
CONTROL-C aborts the entire statement and starts over

Other commands that the LaserWriter will recognize whether in batch or interactive mode are:

CONTROL-C interrupt
CONTROL-D end-of-file
CONTROL-S stop output (XOFF flow control)
CONTROL-Q start output (XON flow control)
CONTROL-T status query
RETURN end-of-line (newline character)
Line-feed (CONTROL-L) same as return

Figure 2.

convert Quickdraw graphics to PostScript and do not have the capability of processing PostScript files directly. One notable exception is a Macintosh application called JustText™.

JustText™ is a professional quality application which uses a command shorthand more familiar to conventional typesetters in place of pure PostScript, compiling this shorthand to PostScript during the printing process. It provides such features as automatic hyphenation and justification of text and the ability to include digitized art in the form of MacPaint files within your document, wrapping text neatly around it in the process. JustText™ also permits you to include PostScript sequences within your file, passing them directly to the output device

during the printing process. Included with the JustText™ application is a utility which will convert MacWrite files, including all formatting codes, to JustText™. I am currently considering development of a similar utility for AppleWriter using WPL and may have it available by the time that you read this article. In fact, this article and the way it was prepared for submission to On Three is an example of how useful such a utility could be. While originally prepared on an Apple ///, it was ported in its final version to a Macintosh, formatted to On Three's specifications using JustText™, output to a LaserWriter and submitted in fully typeset form with no manual pasteup involved. While I probably could have done it all on the Apple ///, some manual pasteup would have been necessary and I would not have had the advantage of JustText™'s automatic hyphenation and justification capabilities.

While this article is by no means intended as a complete treatment of the Desktop Publishing possibilities that exist for the Apple ///, I hope that it has served to open up some new application horizons to you. If you are interested in taking your Apple /// to new heights and exploring the exciting world of Desktop Publishing with it, contact me at:

JAM Graphics
P.O. Box 79
Granby, MA 01033
(413) 467-7722

We can furnish you with a list of service bureaus who may accept your ASCII text files for processing via modem or, if you wish, can process your PostScript files from Apple /// formatted disks on our LaserWriter Plus. (You're not likely to find that service very many other places!) Sorry, we are not set up to accept files via modem at this time, but may add

that capability in the near future.

I do not claim to be an authority on PostScript by any means. If you would like to learn more about PostScript, Addison-Wesley has published two books on the subject and I am sure that many others will follow. The PostScript Tutorial and Cookbook contains several useful program examples. Don Lancaster's utility, already mentioned, is another outstanding source of useful sample programs. These two sources can give you an excellent start at developing proficiency as a PostScript programmer. Expect to see more articles on the subject from me in future issues. Meanwhile, the following information should help you to locate and obtain further information and assistance.



Suggested Reading:

PostScript Language Tutorial and Cookbook
Adobe Systems
Addison-Wesley Publishing Co.
Reading, MA 01867 \$16.95

PostScript Language Reference Manual
Adobe Systems
Addison-Wesley Publishing Co.
Reading, MA 01867 \$22.95

Personal Publishing Magazine
P.O. Box 390
Itaska, IL 60143
\$30/year subscription rate

Inside LaserWriter
Apple Computer Mailing Facility
467 Saratoga Ave., Suite 621
San Jose, CA 95129 \$75.00

Apple // Software usable on the Apple ///:

AppleWriter/LaserWriter Utilities
Synergetics
P.O. Box 809
Thatcher, AZ 85552 \$49.95

**ON THREE is
Your Apple ///
Support Group**

Products & Services Available for the Apple ///

Current ON THREE Price List			
Product	Software	Price	S/H
Disk Of the Month		\$14.95	\$2.00
Two or more DOM's		\$12.50 ea	\$4.00
/// E-Z Pieces		\$135.00	\$3.50
Apple Fortran /// (requires Pascal)		\$99.00	\$5.00
Selector /// program switching utility		\$99.00	\$7.00
Lazarus /// file recovery utility		\$49.95	\$2.00
Unprotect Driver		\$19.95	\$2.00
Desktop Manager		\$129.00	\$6.00
Desktop Manager/ON THREE O'clock combination		\$173.95	\$8.00
Disk Manager* (utilities)		\$44.95	\$3.00
Grafix Manager**		\$49.95	\$3.00
Macro Manager *		\$44.95	\$3.00
Spelling Manager**		\$79.95	\$3.00
ASCII Conversion Table*		\$9.95	\$3.00
Draw ON ///		\$179.00	\$5.00
Draw ON /// Graphics Tablet Version		\$229.00	\$5.00
Fruit Machine (slot machine game)		\$19.95	\$2.00
Card Machine (blackjack game)		\$24.95	\$2.00
Fruit Machine/Card Machine combination		\$39.95	\$3.00
Sandman ** (arcade game)		\$29.95	\$2.00
Crossword Scrambler		\$19.95	\$2.00
UniDisk ///.5 disk and documentation only		\$50.00	\$3.00
Sider 10, 20 mb			
Driver and documentation only		\$100.00	\$3.00
Hardware			
ON THREE O'Clock		\$49.95	\$3.00
Game Card ///†		\$49.95	\$2.00
Apple //e Mouse and Interface card (Use with Draw ON and Desktop Manager)		\$150.00	\$5.00
Apple /// UniDisk ///.5 (800K 3 1/2" disk drive w/ interface, driver & documentation)		499.00	\$10.00
MicroSci A3 140K Disk Drive†		\$225.00	\$6.50
MicroSci A143 560K Disk Drive†		\$325.00	\$6.50
Reconditioned 512K Apple /// w/monitor ///		\$1148.00	\$50.00
256K Apple /// w/monitor		\$749.00	\$50.00
512K Memory Upgrade, 256 to 512K (Remit \$449 and \$50 cash or \$60 credit is rebated when old board is returned)		\$399.00	\$10.00
256K Memory Upgrade, 128 to 256K, no rebate		\$200.00	\$10.00
Other Services and Products			
512K or 256K Upgrade installation (by appointment only)		\$50.00	
12-issue ON THREE subscription		\$40.00	
ON THREE back issues		\$5.00 ea.	
ON THREE magazine binder		\$14.95	\$3.00
Dust Cover for Apple /// and Monitor ///		\$11.95	\$2.00
Dust Cover as above plus Profile		\$12.95	\$2.00
I ♥ My Apple /// T-Shirts sm, med, lg, x-lg yellow, blue, white, beige		\$11.95	\$3.00
I ♥ My Apple /// Sweat Shirts sm, med, lg, x-lg yellow, blue white, silver		\$18.95	\$3.00
I ♥ My Apple /// Caps		\$5.95	\$2.00

*Background module for Desktop Manager

**Runs as standalone or Desktop Manager module

†Quantity Limited

‡Pricing tentative

California Residents add 6% sales tax.

To order, call Toll-Free (800) 443-8877 / in California (805) 644-3514 or write:

ON THREE, Inc. Order Dept.
Post Office Box 3825
Ventura, CA 93006

Visa, Mastercard, American Express accepted. 3% Surcharge on American Express orders.

Items returned without prior authorization subject to 15% restocking charge.

ON THREE Presents . . .

Sandman

\$29.95

plus \$2 shipping and handling

a new multi-level arcade game by Mel Astrahan

- Use with joystick, keyboard or mouse
- Can be run as a Desktop Manager background module

The objective of SANDMAN is to score as many points as possible. Salvage all of the Apple /// parts discarded throughout the halls of Apple's labyrinthian research lab to receive points. WARNING! The lab is haunted by the ghosts of JOBs. . . if they catch you, you're done for!

Your only weapon against the JOBs is to find the WOZ who wanders about the lab peeking in on various projects. For a short time following a meeting of SANDMAN and WOZ the JOBs turn blue and may be exorcised if you can catch them.

"—Brilliant, colorful and fast moving, Sandman will provide hours of fun."

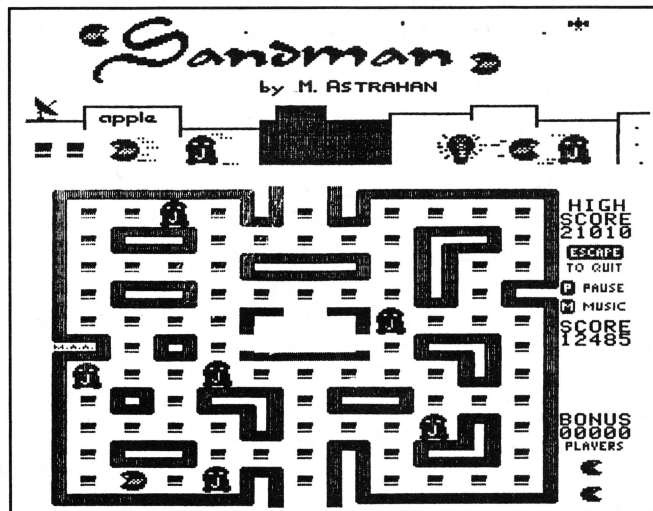

Save more on 512K Upgrades!

Now you can save even more when you purchase the ON THREE 512K Upgrade. If you've read our ads, you know the final cost is \$399 plus shipping, etc., but you remit \$449 plus at the time the order is placed and \$50 is rebated when we receive your old board back.

Effective immediately, we are offering our upgrade customers a new money saving option. As before, you may choose to receive a \$50 cash rebate or you may now elect to receive a credit voucher from ON THREE, worth \$60 on any future ON THREE hardware or software product purchases! This will effectively make the cost of your upgrade just \$389, saving an additional \$10, making our upgrade even more attractive to you.

The choice for additional savings is yours. With each 512K Upgrade we ship, we will enclose a form for you to complete and return with your old board. If you want to save \$10, just check the \$60 credit box or, if you have a need for ready cash, mark the \$50 cash box.

We hope our new policy will be of benefit to you.

Hurrah for ON THREE!

ON THREE is America's leading Apple /// support group and independent producer of quality software and hardware products, and ON THREE magazine, America's leading Apple /// magazine is the official publication of ON THREE.

ON THREE magazine contains enlightening articles and programs about Pascal, BASIC, and assembler; technical hints, reviews, material for the novice and the advanced programmer, and in addition, you will always find news of exciting new and current ON THREE products, user group listings and hot line consultants, plus the popular and informative "Three Questions" readers' forum.

Chances are your ON THREE subscription is about to run out. If so, renew now and don't miss out on any of the interesting articles in future issues nor announcements of new and sophisticated ON THREE products. ON THREE Magazine, your bible of Apple /// information. Twelve issues for just \$40.00, back issues available at \$5.00, postpaid.

ON THREE (805) 644-3514
P.O. Box 3825, Ventura, CA 93006

Name _____
Address _____
City _____
State _____ Zip _____ Phone _____

enclosed \$ _____
 M/C Visa AE* NEW RENEWAL
number _____ exp. date _____
Signature _____
*3% surcharge on American Express.

Terminus

john r. sollman

There has always seemed to be an aura of mystique surrounding communications programs for microcomputers. This is understandable, when one considers that there are more "moving parts" in a telecommunications program than in other computer applications. There are two computers instead of one, two modems, two sets of communications software, a telephone link via voice or data grade lines, and sometimes an intermediate carrier such as Telenet or Tymnet. When one reads the manuals, one is confounded with talk about bit streams, handshaking, full or half duplex, echoing—the list is almost endless. The bottom line is that there are many more variables involved than when simply using one's own computer and software comfortably isolated from the rest of the world. When entering the world of telecommunications by computer, all the variables on each player's turf must be made to work together.

For the Apple /// owner the problem is compounded by a general lack of communications programs. Most Apple /// users probably started out with Access ///, a basic communications program which would get the job done without any bells and whistles. Access /// did not offer the ability to create communications sets with built-in protocols and macros. If the terminal being communicated with required a protocol different from the default, it was necessary to change the system parameters each time that terminal was to be accessed. If the Apple /// user wanted the ability to create communications sets containing macros, he either had to write a program in Pascal or BASIC which would do this, or look for other software. (Now, *Macro Manager* will help out somewhat.)

Several years ago, while it was still actively creating Apple /// software,

About the Author...

John Sollman was born September 13, 1931, in Los Angeles, spending his early childhood in Missoula, Montana, later in New York City and Portland, Oregon. At 17, he joined the Navy and became a Hospital Corpsman. His hitch included service with the 1st Marines in Korea, landing at Inchon in September, 1950. In 1956, he earned a Medical Service Corps commission and in 1969 retired with the rank of Lieutenant Commander. His first real contact with computers and number crunching came in 1958.

After retirement, Sollman went to work for the Oregon Workers' Compensation Department as a disability evaluator, later serving as Evaluation Administrator. In 1975, he was assigned to run the department's rehabilitation program.

Sollman left there in 1979, and began practice as consultant in compensation and rehabilitation. He acquired an Apple /// in December, 1982, and began analyzing vocational and labor market information, using facilities of Ability Information Systems, Inc., in Spokane, Washington. He presently provides consulting service and performs vocational analyses for several Oregon rehabilitation firms. Sidelines include a resume and word processing service, and maintenance of catalogs and mailing lists.

Quark created its Terminus communications program as an external procedure to be invoked from within Word Juggler. The software is contained on a diskette which can be copied, and is accompanied by a manual contained in a nine- by eight-inch three-ring binder.

Terminus requires a 128K Apple /// and Word Juggler. If one is using Catalyst Version 2.0 or greater, a 256K machine is required. In addition, there must be a modem connected to the serial port or a serial interface card, and the appropriate serial driver must be installed on the boot diskette or loaded dynamically from Catalyst.

The current version of Terminus is 1.2, and is still available from Quark for \$89.00. Those with versions 1.1 or 1.0 of Terminus may upgrade to version 1.2 by returning the original Terminus diskette to Quark, attention Warranty Service, accompanied by a check for \$49.00. The upgrades fix a problem encountered when using the 128K Apple /// (1.1), and extend from one to two seconds the pause for a subsequent dial tone or carrier signal when a pause (for Hayes users, a comma) is inserted in the auto-dial string (1.2).

In addition to a default communications set which does not support

the use of macros, Terminus allows the user to create up to 15 different communications sets. (The manual refers to these as protocols.) Each user-created communications set contains two automatic macros for auto-dial and logon, and may contain up to 26 invocable macros of up to 48 characters each. The macros can be chained if necessary. The program permits editing communications sets and macros as needed, and allows temporary changes to be made to the communications protocol while in a communications session. Terminus permits capturing a communications session to printer or disk, and allows the capture feature to be toggled on and off as required.

The first step in installing Terminus is to make a copy of the original diskette and store the original in a safe place. All installation then proceeds from the copy. Nothing should ever be written to the original diskette. For non-Catalyst users there is no installation as such. You simply boot Word Juggler and replace the boot diskette with the Terminus diskette copy. If Word Juggler has been properly configured, it will look to the internal drive for the necessary files when Terminus is invoked.

For Catalyst users, there is an automatic installation procedure. After booting Catalyst, simply place the Terminus diskette copy in the internal drive, select Catalyst Editor from the main Catalyst menu, then select option 6 to install the program. From the menu which will then be presented, select option 1, Install a Quark Program. The next menu lists available Quark programs, from which you select option 3, Terminus. The Terminus diskette has a QUARK.INSTALL file which then carries out the necessary steps.

Actually, installation could be accomplished almost as easily by copying three files from the Terminus diskette to the WJ subdirectory on .Profile (or whatever hard disk you are using). The three files to be copied are the codefiles WJ.EXT4 and WJ.EXT5, and the ASCII file TS.PARAMS. The installation diskette also contains the current version of the RS232 driver and an ASCII file called TECH.NOTES which can be printed out and used for further reference.

The file, TS.PARAMS, stores the individual communications sets with their associated protocols and macros. This file can be copied to a backup floppy disk occasionally, so that the information can be restored to the hard disk if the file is ever corrupted. As delivered, the installation diskette contains five sample communications sets. The first of these is for Apple Serve /// (Remember Apple Serve ///?) One other complete set is supplied for The Source, followed by a terminal set-up for Terminus-to-Terminus communication and autodial examples for the Hayes

Smartmodem and SSM TransModem A-dial. TECH.NOTES shows each of the examples in detail, and provides further explanation.

There are actually two programs associated with Terminus; these are invoked by simultaneously depressing the closed-apple key and a key on the numeric keypad. A configuration program, invoked by depressing closed-apple-4, permits you to create, modify or delete communications sets and macros. Depressing closed-apple-5 invokes the communications program itself.

When closed-apple-4 is depressed, the following menu appears:

TERMINUS CONFIGURATION PROGRAM (VERSION 1.0)

OPTIONS:

1. ADD - CREATES A NEW PROTOCOL.
2. EDIT - MODIFIES A PROTOCOL.
3. DELETE - REMOVES A PROTOCOL.
4. SET MACROS - DEFINES MACROS FOR A PROTOCOL.
5. SET DEVICE - CHANGES THE DEVICE DRIVER NAME.

From this screen, you may add, edit, or delete an entire communications set and its associated protocol and macros. Item 5, Set Device, is used only when a driver other than the RS232 driver, such as a special serial card driver, is used. This option would rarely be used. Most commonly, after becoming familiar with the software and the documentation, one would start by adding a new communications set. (Quark uses the term, "Protocol," in a broad sense to mean a communications set, as indicated in the above menu. The term is also used to mean an actual protocol (XON/XOFF, Hardware, etc.) to control the exchange of data

between two terminals. I prefer to use the term, "Communications Set" instead of Quark's broader use of the term, "Protocol.") Selecting option 1 would produce the following screen:

TERMINUS CONFIGURATION PROGRAM (VERSION 1.0)

ADD

NAME:

ECHO: ON

SEND LF: OFF

PARITY: NONE

BAUD RATE: 300

HANDSHAKING: HARDWARE

PREFIX:

USE ↑ AND ↓ TO SELECT FIELD TO MODIFY.

ENTER NEW VALUE AND PRESS RETURN TO CHANGE.

The protocol shown is identical to the protocol in the default communications set. Any protocol may be changed temporarily while the communications set is in use, but may not be permanently changed. The protocol for the default communications set may never be permanently changed. The user may create up to 15 named communications sets, complete with auto-dial sequences and macros. The first step in creating a communications set is to provide a name. There is no default for this value, and a communications set cannot be created without assigning a name.

Terminus has greatly simplified the process of defining values in the communications protocol. In Terminus, the user may modify only certain key values. After using the program for two years, I find that the choices offered are perfectly adequate for my communications purposes. Quark's approach is in contrast with some other communications programs which may tend to be very critical of protocol values. The newest version of Hayes Smartcom II, for example, even requires the type of monitor in use to be correctly entered in its configuration program. Terminus has no such requirement to be "fine tuned." I have found no need, for example, to select seven- or eight-bit

ON THREE Presents . . .

LAZARUS ///

File Recovery System

- *A wrong keystroke can lose hours of work*
- *The correct keystroke with Lazarus /// can undelete those lost files. Need we say more?*

\$49.95 plus \$2 s/h

- *Not copy-protected—Installs easily on Selector ///, Catalyst*

Apple /// System Configuration Program		19 Oct 86 5:37:12 PM														
Edit Driver Configuration Block																
	0	1	2	3	4	5	6	7	8	9	A	B	C	D	E	F
Ox -	08	22	00	00	00	00	13	11	DF	84	50	00	-	-	-	-

figure 1

transmission modes from within Terminus. In ASCII transmission only seven bits are used. The eighth bit may be used for parity or ignored, depending upon the protocol selected. One can always use System Utilities to change the default bit configuration in the driver file, if desired.

While on the subject of drivers, the Terminus diskette contains a current version of the RS232 driver, and the Terminus manual tells how to install it if need be. The manual makes no recommendations as to the proper settings for the Driver Configuration Block. This is probably because the default settings will work satisfactorily. When I got my 1200 baud Hayes Smartmodem, I changed the first value in the DCB to 08 (1200 baud). When I installed Terminus, I made no further modification to the RS232 driver. In fact I never paid any attention to it at all, other than to be sure it was there when needed. My DCB is shown in figure 1, and it works just fine.

A check with the Standard Device Drivers Manual will show that the above settings support 1200 baud; 7 bits odd parity; no delay for carriage return, line feed or form feed; no protocol; control characters for XON/XOFF protocol; buffer range from maximum of 223 characters down to minimum of 132; data block length of 80 characters; and no hardware handshake. Certain of these settings, such as baud rate, protocol, and handshaking, will be modified as the program is run. Others may be tinkered with by advanced users to "fine tune" their systems' communications capabilities. For the average user, however, no such tinkering is necessary.

Settings in the configuration menu are changed by using the left or right arrow keys. Probably the most critical item is ECHO. My Hayes Smartmodem 1200 is factory set to echo when in the command mode, but not

to echo when in the communications mode. Most host programs will echo back the data received. When you turn echo off, you see each character on the screen as it is typed. If the host program is echoing, you will see each character again as it is echoed back from the host computer—two characters for each character typed. If your modem also happens to be echoing, you will see three characters for each character you type. With echo turned on, you will not see the character on the screen when you type it, only when the echo from the host computer arrives back at your terminal. In other words, you see what the host computer has received and sent back, not necessarily what you have sent. This accounts for the slight delay between keyboarding a character and seeing it appear on your screen. It also lets you know if there is interference on the line in either direction. Anyone who has ever used a modem is well familiar with communications garbage.

Line feed, parity, baud rate and handshaking are likewise set by using the left or right arrow keys to scroll through the possible settings. With line feed, there are only two possible settings; with parity there are four: None, Odd, Even, and Mark. Baud rates available are 110, 300, 1200, 2400, 4800, and 9600. There are also settings to permit extra delay (insertion of extra stop bits) for 300 and 1200 baud. For handshaking, the choices are Hardware and XON/XOFF. One is well advised to use the default settings for parity and handshaking when starting out on the system. These will work for most applications. From a practical standpoint, you use what works. Sometimes trial and error are necessary to get the settings just right. If you find, for example, that one line keeps overwriting itself, press 0 on the numeric keypad, move the cursor to SEND LF and press the right arrow.

One can change any value except name and prefix while communicating. These changes are temporary, and notation should be made as to which settings worked so that they may be entered permanently later on (*Notepad* to the rescue).

In my own business, I do a great deal of communicating with a vocational data base in Spokane, Washington. To get there, it is necessary to use voice grade circuits for the fifteen miles from my home to Salem, Oregon, thence by data grade circuit from Salem to Spokane via Tymnet. Occasionally, I communicate with the *ON THREE* Bulletin Board, usually to upload magazine articles or other writings. To get to *ON THREE*, it is all the way from Silverton, Oregon, to Ventura, California, by voice grade circuit. Silverton is served by a lesser telephone company with a brand-new pulse code modulation switching facility. During the day there is a tendency toward some on-line garbage; at night the circuits are quieter. I have found that I experience virtually no data loss when communicating at 1200 baud set for extra delay. When trying to use the full 1200 baud, I found that communications garbage tended to be more of a problem, and there was some occasional loss of data [*Editor's note: for example, this file, consisting of about 27,000 characters, was uploaded to our BBS with only three "glitches," consisting of about one word each.*]

The Configuration Menu permits the designation of a prefix for sending or receiving files. Such designation is optional. If no prefix is designated, Terminus will use the prefix which has been set for Word Juggler. Whether a prefix has been designated or not, the user can always enter a complete pathname when opening a recording file.

After selecting the protocol settings, pressing the space bar saves the settings and returns you to the Configuration Program Main Menu. You can then set up macros for automatic execution of many functions. Selecting option 4. SET MACROS -DEFINES MACROS FOR A PROTOCOL, brings up a menu of existing communications sets. In my system, the menu looks like this:

**TERMINUS CONFIGURATION PROGRAM (VERSION 1.0)
SET MACROS**

PROTOCOLS:

1. TYMENET INFO
2. The Source (1200 baud)
3. Terminus to Terminus (1200)
4. Hayes Autodial Example
5. On Three Bulletin Board
6. AIS

From the menu you select the communications set for which you wish to create, modify, or delete macros. The following menu will appear:

**TERMINUS CONFIGURATION PROGRAM (VERSION 1.0)
SET MACROS**

MACROS FOR PROTOCOL: Terminus to Terminus (1200)

1. Autodial	M.
2. Logon	N.
A.	O.
B.	P.
C.	Q.
D.	R.
E.	S.
F.	T.
G.	U.
H.	V.
I.	W.
J.	X.
K.	Y.
L.	Z.

Normally, the first macro to be set up is the Auto-dial. Shown below is the auto-dial macro which supports my communication with the AIS database via Tymnet:

**TERMINUS CONFIGURATION PROGRAM (VERSION 1.0)
SET MACROS**

PROTOCOL: AIS

MACRO: 1

NAME: Autodial

TEXT: ATDT15850182M<CONNECT>

CONTINUATION:

USE ↑ AND ↓ TO SELECT FIELD TO MODIFY.

ENTER NEW VALUE AND PRESS RETURN TO CHANGE.

As with the configuration menu, the up and down arrow keys are used to select the fields to modify. Each

macro has a provision for a continuation to another macro. Macro 1, Autodial, automatically continues to Macro 2, Logon. Therefore, it is not necessary to enter the number 2 in the continuation field. To do so, as a matter of fact, produces a rather unusual result. The chained macro execution is frozen, and open-apple-escape must be used to clear the execution buffer. The above macro demonstrates another peculiarity of Terminus. When a "Connect" is sensed, macro execution proceeds to Macro 2, Logon. It happens so fast that the host system does not have a chance to send out its next prompt before Macro 2 executes. This also causes macro execution to hang up. The matter is nicely resolved by entering an immediate wait string following the telephone number. A wait string suspends macro execution until a particular character or string of characters is received from the host computer. An immediate wait string is executed one time, then macro execution continues. A permanent wait string continues to be executed until canceled. The permanent wait string is most useful in uploading information to a host computer. It causes the computer to wait for a carriage return or a specific line prompt before transmitting the next line of information.

In the case of the Hayes Smartmodem 1200, the Smartmodem sends the word, CONNECT, in upper case. With an immediate wait string, <CONNECT>, Macro 2 will not be executed until the Smartmodem responds with the word, CONNECT. The letter, M, in the string following the telephone number is a Control-M, or \$0D, the ASCII carriage return character.

To communicate, one simply presses closed-apple-5 on the numeric keypad. You are then presented with a list of communications sets available, similar to the screen for SET MACROS in the Configuration Program. Pressing Return selects the default protocol. When a named communications set is selected, the Autodial macro is immediately executed, followed by the Logon macro. For my communications sessions with the Spokane data base, I use about six or seven macros chained to

Macro 2, Logon. These take me through a complex series of passwords and control codes. In addition, this particular communications set contains several macros designed for individual execution. A macro is executed by pressing open-apple and the letter key assigned to the desired macro.

To record a communication session, one simply presses 5 on the numeric keypad. The program prompts for a pathname. A file name can be entered if the default prefix is to be used, or a complete pathname can be entered if desired. After the pathname is entered, the user is prompted for the type of file to be expected. Two choices of reception mode are possible: Hex File or As Is File. The Hex File mode is used to convert a hex file being transmitted back to its original form. Ordinarily, you will use the As Is File option. When the reception mode has been selected, you are returned to the communications screen. The recording file can be toggled on and off by pressing 6 on the numeric keypad. By pressing 0 on the numeric keypad, you can see whether your recording file is on or off. Each time the recording feature is toggled on, the reception mode must again be selected. If desired, one can send the record of the communications session to the printer instead of a file. You simply designate .PRINTER (or whatever your printing device is called) when prompted for a pathname.

Sending or uploading a file is also simple. You press the "." key on the numeric keypad. You are then presented with three choices of transmission mode: Hex File, As Is File, or Document in Memory. Hex File converts binary data into lines of 60 hexadecimal digits each. The As Is File is a file on disk, being transmitted as is. If either of these alternatives are selected, you are prompted for a pathname. If the As Is File on disk is a Word Juggler file, it will contain control codes which would appear as trash to a non-Word Juggler user. If a file is to be transmitted As Is, it is better to store it as an ASCII file first. If the third option is selected, Document in Memory, the program transmits the document in the computer's memory, less control codes, i.e., as an ASCII file.

There is a special mode for communications between two computers using Terminus. To use this mode, the receiving computer sets the record function by pressing shift-5 on the numeric keypad. A pathname is prompted for, followed by a choice of three reception modes. The additional mode offered is called Compressed. The transmitting computer selects the special transmission mode by pressing [shift-.] on the numeric keypad. The sender also has the additional choice of transmitting in the Compressed mode. The settings on the two computers must be compatible. Compressed or Hex File must agree on both ends. If the sending computer transmits either As Is File or Document in Memory, the receiving computer must be set to receive As Is File.

Whenever Terminus prompts for a pathname, it is possible to look at a directory by typing ? for the default directory, or ? followed by the pathname for another directory. When recording in Terminus, there is no warning if a file is to be overwritten. It is therefore advisable to know the contents of the directory where the file is to be stored.

The next logical question to ask is, "How does it work?" The answer to that question would be "Exceedingly well." After using Terminus for two years, I would never go back to using Access ///—not willingly, at least.

Like all programs, Terminus has many strong points and some weak ones as well. For its strengths, I like the communications sets which automatically dial the number, connect you with the host computer, and run through any sign-on procedure. This is the kind of stuff one forgets if one does not communicate with a particular host computer very often. In Terminus, one keystroke does it all. Special macros can be designed to perform utility functions, such as hanging up the modem. (For the Smartmodem, the following macro will do this: +++<OK>ATHM). This saves some keystrokes, and may help to reduce your bloated telephone bill as well. One of the nicest features of Terminus is that it tends to be forgiving if not fine tuned. There are other programs out there which are not so forgiving.

There are some weaknesses which we will have to live with, since Quark does no further development work on programs for the Apple ///. It is not possible to copy a communications set in order to edit a new set out of an existing one. It is not possible to incorporate a specific time delay in a wait string. The wait string will recognize only the designated characters. Only 15 communications sets can be established, as compared with 25 for programs like Hayes Smartcom II. There is no status line on the screen to indicate recording status, file name, or printer status.

The manual is the weakest feature of Terminus. Regrettably, this is true of most software on the market today. For an industry which requires such precision and logic in creating an application software package, it is inconceivable that the same precision and logic cannot be extended over to the writing of plain, understandable English. The manual for Terminus is poorly organized and only adequately written. The manual is written as a tutorial. The reader is walked through the major features, and then taken again through the same features in a more detailed fashion. There is an index of keystrokes, but it is not complete. There is no reliable index by program function to show the required keystrokes. (I prepared my own for the time I was learning to use the software.)

One of my pet peeves is that most software manuals do not explain program structure and file relationships. Terminus is no exception. Also, there is no one place in the manual which lists the limitations of the software. To find out how many communications sets are permitted, one would eventually find the answer stated in an "Oh, by the way" fashion at the bottom of Page A-2 in the section dealing with errors and recovery. Likewise, the number of characters permitted in a macro is buried in the text at the top of page 4-4. The use of language is fuzzy. The term, "protocol" is used in the manual not only to define the type of handshaking between two computers, but also to describe what should be referred to as a communications set.

Most of my use of Terminus has been to download information from the vocational data base in Spokane. Although I have uploaded documents on occasion, this is not a prime activity for me. My equipment is used strictly for business purposes, and time is spent wallowing around in a bulletin board only when it has some connection with my work.

Recording a session works just as you would expect. Toggling the record feature on and off is relatively simple, but not as simple as in Access ///. The greatest danger is in retrieving a file which is too large to load into Word Juggler. It is easy to change the recording file in mid-transmission.

You simply send a Control-S which stops everything in its tracks, press 5 on the numeric keypad, give the new pathname and select the reception mode, press Control-Q, and you are back in business. Sending a file is easy. Usually you will be sending a document in memory. After you have reached the place for uploads in the bulletin board, you simply press "." on the numeric keypad. Then you sit there and watch your file go by as it is echoed back from the host computer.

I have not had the opportunity to test the software by communicating with other microcomputer users. Specifically, I have not had the opportunity to test the Terminus-to-Terminus communications capabilities. If that is like everything else, however, it should work just as advertised.

One of the greatest conveniences, and at the same time one of the greatest weaknesses, is the status of Terminus as an external procedure invoked from within a proprietary word processing program. It cannot stand alone, and it will only work as an invocable module from within Word Juggler. For Word Juggler users, however, at the \$89.00 price you can't go wrong. After having used this software for two years, I am entirely satisfied with its performance. While the manual leaves a lot to be desired, seasoned Word Juggler users should quickly learn to use the many features of Terminus.



ON THREE Presents...

The Desktop Manager™

by Rob Turner and Bob Consorti

- The most complete and sophisticated desk accessory program ever written!
- For once and for all, unclutter your desk the Desktop Manager way!

The screenshot shows a spreadsheet with columns for 'Straight Line', 'Declining Balance', and 'Double Declining Balance'. Each column has sub-columns for 'years', 'dep', and 'res'. A 'Desktop Manager' menu is overlaid on the right side of the spreadsheet, listing various utilities like Calendar, Calculator, Macro Manager, etc.

Desktop Manager main menu, shown overriding a spreadsheet.

Running in the background, the Desktop Manager places all of the desk accessory utilities you ever wanted... Appointment Calendar... Notepad... Calculator... Disk Utilities... Macros... Graphics... Games... and more, into each program you own, just like they were part of it. Instantly available from /// E-Z Pieces, VisiCalc, AppleWriter, BPI, and all other programs, the Desktop Manager will clear your desk pronto.

What is "Running in the background?" It is simply a program that, unlike most, "hides" from you. You are never aware of its presence, but when you need it, it is "Johnny on the spot," ready to serve you at the touch of a key.

While word processing, have you ever needed to multiply two numbers? Perturbed because you have a few thousand dollars worth of computer equipment at your fingertips and still can't multiply two figures when you want to? Or, you're entering data in a spreadsheet and can't find either a scratchpad or a pen to jot down a note. While you're digging under piles of paperwork, you probably mutter something unprintable under your breath.

Perhaps you're entering text in a word processor document and decide it's time to do your first file save, but you can't remember if the file name you want to use already exists. Too bad the word processor has no provision to catalog a disk. Similarly, you may need to save a file and discover that you don't have a disk with enough room left on it. You have

plenty of blank, unformatted disks. If you exit the program to use the System Utilities to format a disk, all of your work will be lost.

Does this describe your situation? How about clearing your desk of that old-fashioned calculator, the pens and paper, your appointment calendar and increase your productivity? The Desktop Manager from ON THREE will do these things and a great deal more. From within any program, a keypress will override your current application and display a window into the Desktop Manager. At this point you have the entire facilities of the Desktop Manager at your beck and call. You can pause whatever you are presently doing, and select any of the following modules:

The screenshot shows a database window with a list of dealers. A 'HELP MENU' is overlaid, listing 'General Commands' and 'Editing Commands'. The database data includes columns for 'DEALER', 'STATE/ZIP', and 'REGION'.

NotePad main help menu, superimposed on a NotePad memo and a database.

The screenshot shows the same database window as the previous image, but with a 'SECONDARY HELP MENU' overlaid. This menu provides more detailed instructions for the 'General Commands' and 'Editing Commands'.

NotePad secondary help menu, superimposed on a NotePad memo and a database.

The Note Pad: A powerful and easy to use work processor. It lets you jot down notes for quick reference while you are entering data or for later viewing. No need to type in a file name, The Notepad does it for you, automatically. Multiple pages per note, plus the sophisticated features of word-wrap, automatic repagination, copying and more gives you the power of a word processor—available in an instant—from whatever program you are using. Instant on-line help screens (a feature of all Desktop Manager modules) make The Notepad easier to use than many word processors.

The screenshot shows a calendar grid for May 1986. A pop-up window titled 'Appointment Calendar' is displayed, showing a list of appointments and a summary of appointments for the day.

Appointment Calendar primary display.

The screenshot shows a detailed view of an appointment event. It displays the appointment name, date, and time, along with a table showing the declining balance and double declining balance over a period of years.

Appointment Calendar event, showing an appointment that has just come due.

The Appointment Calendar: A time scheduling productivity tool that allows you to set multiple appointments for any day through December 31st, 1999. These "Appointment Events" automatically notify you of your next appointment. From within any program, no matter what you are doing, the Appointment Calendar will pop up on your screen and display your next appointment. The day and week at a glance features show the appointments for a single day or an entire week. It also provides an easy way to set your system clock. Full help screens compliment this handy and easy to use perpetual calendar.

The Calculator:

An extremely powerful electronic workhorse. Full 16-digit accuracy and multiple functions like: SIN, COS, TAN, LOG's, x to a power, square roots and more. In addition to the basic add, subtract multiply and divide, The Calculator features e, pi, degrees and radians, memory, base conversions from decimal to hex or binary and back again, a simulated scrolling paper tape, hardcopy printing and of course, on-line help screens.

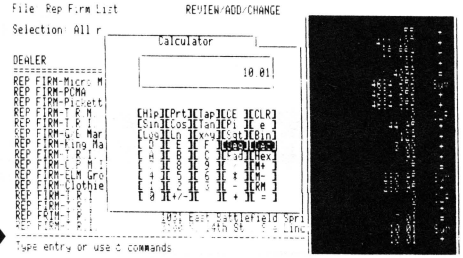

The Calculator, with paper tape showing last calculations. →

The basic **Desktop Manager** comes complete with all the above features and more! For the first time, **Desktop Manager** lets you use a mouse from within any program, even those not designed for a mouse. You will be able to use the mouse to move the cursor and the mouse button doubles as the ESCAPE or RETURN key. The **Desktop Manager** also offers the ClipBoard for information transfer. With the ClipBoard, you can transfer information from one screen or program to another. Say you are using the Calculator to do some calculations and want to transfer the result into your word processor. You can simply cut from the calculator and paste it into your program. Likewise, you can move an entire section of text from your program to the notepad or vice-versa.

In addition, if you are running with Selector /// or Catalyst, you can also transfer directly from one application to another. After you have used the

ClipBoard to transfer some information, you can return to your previous application by simply pressing Escape, and the cursor will even be exactly where you left it.

With our no-nonsense installation program, a few simple keypresses will quickly install the **Desktop Manager** on all of your application programs. No need to use the System Configuration Program, Desktop Manager does it all for you, and automatically! All **Desktop Manager** Modules have movable windows that can be placed anywhere on the screen that they will fit.

The complete package includes all of the features described above and a 110 page User's Guide that shows clearly how to use each function of the various **Desktop Manager** modules. Priced at only \$129 plus \$6 shipping, the **Desktop Manager** is the best thing to happen to the Apple /// in a long, long time.

Disk Manager™

Provides the most frequently used features of the Apple /// System Utilities program. Formatting disks, listing, copying, deleting and renaming files and more are all available, at the touch of a button. Never again will you have to lose data when you need to exit a program to format a blank disk. On-line help screens and standard **Desktop Manager** "Ease of use" makes the \$44.95 (and \$3 shipping) price a steal.

Optional Desktop Manager Modules Available Now!



Main menu of the Disk Manager

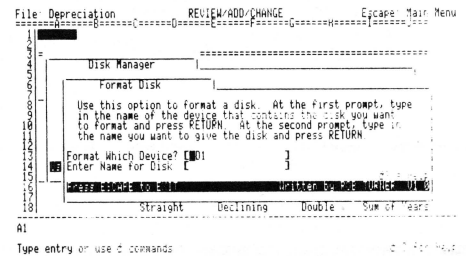

"Format a Disk" option of the Disk Manager

Macro Manager™

Allows you to define a single keypress as a series of keystrokes to be played back at your command. Our innovative Record Macro mode lets you record a series of keystrokes—over 2000, if you want—right while you type them in response to prompts, etc., in an applications program. After you have finished choosing from your applications menu, you can go right back to the Macro Manager and assign the previously recorded keystrokes to a single macro definition. Up to 50 different definitions can be assigned to a single macro set. Each set of macros is called a MacroMap™ and over 200 different MacroMaps, which can be modified with additions and deletions, etc., can be selected from an easy to use menu. The Macro Manager allows you to copy macros from one key to another and to exchange or re-assign macro keystrokes. All of this and more for only \$44.95 plus \$3 shipping.

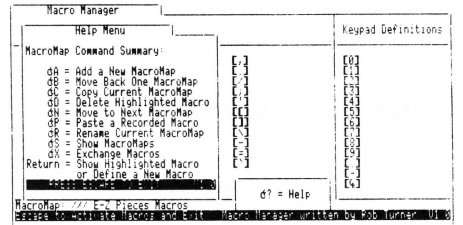

The Macro Manager's help menu, displayed over a MacroMap™

ASCII Chart:

Lists, in an easy to understand table, the decimal and hexadecimal values for all ASCII characters. A second screen features a keypress table that shows exactly which keys to press for different ASCII codes. The keypress table can be a lifesaver when you need to know what commands to send to a printer, or to an applications program, to enable different printing modes such as bold, italic, compressed print, etc. Only \$9.95 plus \$3 shipping. As an extra bonus, the source code is included on the disk.

Mr. SandMan:

A fast-moving, multi-level, full-color arcade game that you can play at any time. As a **Desktop Manager** background module, whenever you need a break from the tedium of entering data into your present application, you can instantly "take five" to team Mr. SandMan up with the wandering WOZ and eat up those nasty JOBS in this challenging and amusing game. For only \$29.95 and \$3 shipping, you will receive both the **Desktop Manager** and stand-alone versions. The stand-alone version allows you to play Mr. SandMan even if you don't have the **Desktop Manager**.

Available Now!

Graphics Manager™ and Color Graphics Manager™

Send graphic images you create with any Apple /// or Apple //e program to your printer. Insert a picture in the middle of your word processing document at any point, in any size with Graphics Manager's automatic rotation and image enlarging/shrinking features. Layout newsletters, combining text and graphics on the same page. Create a personalized letterhead with Draw ON and use the Graphics Manager to merge it with your word processing document. The Color Graphics Manager supports the ImageWriter II, IDS Color Prism, Epson JX and the IBM PC Color Printer and works with any interface card and graphics-compatible printer.

The **Desktop Manager** requires an Apple /// with 256K or 512K of memory and an external disk drive of any type or capacity. The Appointment Event feature requires an **ON THREE O'Clock**, an Apple Clock or compatible Apple /// clock chip. The **Desktop Manager** uses between 32 and 40K of memory.

Desktop Manager	\$129.00
	plus \$6 s/h
Disk Manager	\$44.95
	plus \$3 s/h
Macro Manager	\$44.95
	plus \$3 s/h
ASCII Chart	\$ 9.95
	plus \$3 s/h
Mr. Sandman	\$29.95
	plus \$3 s/h

ON THREE Presents . . .

Spelling Manager™ \$79.95

plus \$3.00
shipping/handling

3. All...
lead, poured from a...
< OE *picga.)
n (pij'an) n. 1. Any of various related
with a deep-chested body, a small head,
short legs, esp. a common, often domesti-
species. 2. Slang. One easily swindled; a
pigeon-hole (pij'an-höl) n. A small compart-
ment, as in a desk. -v. -holed, -holing. 1. To
put or file in a pigeonhole. 2. To categorize.
To put aside and ignore.
geon-toed (pij'an-töd') adj. Having the toes
turned inward.
pig-ish (pig'ish) adj. Like a pig; greedy.
piggy-back (pig'e-bäk') adv. 1. On the shoul-
ders or back. 2. By a method of transportation
in which truck trailers are carried on trains.
-piggy-back' adj.
pig-head-ed (pig'héd'id) adj. Stubborn.
pig iron (pig'irən) n. 1. A coloring substance
or matter. 2. A substance, such as chlorophyll
or hemoglobin, that produces a characteristi-
color in plant or animal tissue. [L pigmentu-
to paint.]

- Spell-check any /// E-Z Pieces document
- 80,000 words instantly available
- Plus medical, legal dictionaries soon
- Complete package includes full documentation, Desktop Manager™ module and standalone version

order toll-free: (800) 443-8877
in California: (805) 644-3514

... from ON THREE

Keep all of your
ON THREE magazines
in one place in
our handy binder.

- Holds 12 issues
- Always Available
- Practical
- Attractive
- Convenient

Blue print with
gold trim on
sturdy, re-inforced
white vinyl.
Only \$14.95
plus \$3
shipping/handling

A great gift idea for
your favorite Apple ///'er!

Order now on our new toll-free line
(800) 443-8877 (except California)

ON THREE presents...

The Unprotect Driver \$19.95 plus \$2 s/h

ON THREE has not changed its position regarding duplicating copyrighted programs for profit or to give away, but since many Apple /// software products are no longer supported, owners of AppleWriter ///, VisiCalc, and VisiCalc Advanced Version are facing the problem of what to do when a diskette "crashes." After much consideration we decided to proceed with a product to solve that problem. *The Unprotect Driver* will allow you to make back up floppies of the above programs. For the first time, you can put your master disk in a safe place and boot on the duplicate.

Economically priced at only \$19.95 plus \$2.00 shipping and handling, the *Unprotect Driver* comes with full documentation and will work with *Selector* /// so you will no longer require a "key" diskette. The *Unprotect Driver* is sold for legitimate *Archival* purposes only. **ON THREE does not condone** and will not condone duplicating a disk for any other purpose.

Merging Files

phillis fox

"Finally," I thought, "Something useful for the /// from my Apple dealer!" I had just received a set of brief, seemingly clear instructions on how to merge Quick File files. The idea, according to the instructions, was to print label-style reports to diskette, merge the ASCII files, and then rewrite the newly merged file back to Quick File using either a Pascal EXEC file or Grabit ///.

Although the instructions promised that I could get a copy of Grabit /// from my dealer, I have never been able to do so. Meanwhile, I set about trying to merge files using Pascal EXEC files. I soon discovered that the instructions were not succinct so much as they were cryptic, ignoring half a dozen pitfalls. After many hours of trial and error (my fragile ego prevents my from saying exactly how many), I filled in the gaps in the instructions.

Here is what I learned. Pascal users, follow these instructions step by step, and you too can merge files.

Instructions for Pascal Users

Step 1: Make Sure You Have the Appropriate Disks Ready

To merge files using this procedure you need Quick File (obviously) and Pascal. Remove any extraneous files from your Quick File Program disk. You will need plenty of space if you are merging large files. You need a disk on which to store the new Quick File files that will be created. Also have ready a Pascal2 or a NewPascal2 disk with as many free blocks as possible. Consult *Apple /// Pascal: Program Preparation Tools* if you have questions on how to configure Pascal disks.

Step 2: Make a Label-style Report

Begin by making label-style reports for the files you wish to merge, one report for each file. Your goal is to create a text file on diskette which will contain only the information to be written back to Quick File. Consequently, do not send any messages to your printer, even if you normally must do so. Follow the directions in the Quick File manual and use these Open Apple - O printer options:

- 0-8 = Default modes
- 9 = No, do not send any special codes to the printer. You do not want these embedded in the text file you are creating.
- 10 = No, do not send linefeeds.
- 11 = Yes or no, either dashes or blanks for blank lines work.
- 12 = No, do not stop printing at the top of each page.
- 13 = No, do not print report header at the top of each page.
- 14 = No, do not send form feed commands; you do not want these embedded in the text file.
- 15 = No, do not omit a line when all entries are blank. Option 16 now disappears.

It seems logical to want option 16, which keeps the number of lines the same within each record. That option, however, requires option 15, which omits lines when all entries are blank. The effect of these two options together is to put all blank lines at the end of the record, regardless of where they occurred originally. For example, let's say you have this record:

Name: Don Johnson
Street address: -
City & state: Miami, FL
Phone: -

(You can tell a woman wrote this article, can't you?) With options 15

and 16 in effect, the label-style report will be written with two blank lines at the end of the record:

Don Johnson
Miami, FL
-
-

The city and state are now stored on the line reserved for street address. When the computer writes this information back into Quick File file form, it will write data back to the incorrect category.

When you are ready to print your label-style report, you are asked to choose a name for your report. Whatever name you choose for your label-style report will have ".ASCII" automatically added to it. Choose option 3, write to a file on disk. This process is quite slow and will take a long time if your file is large.

Step 3: Prepare an Empty File

While still in Quick File, prepare a blank file which will be used to store the merged file once it is created. Follow the instructions in the Quick File manual on how to create files. The categories in this blank file must be identical to and in the same order as the categories of the files to be merged. Do not insert any records into this blank file. Once you have created the file, save it onto a Pascal2 or a NewPascal2 disk.

Step 4: Quit Quick File and Go to Pascal

Still in Quick File, return to the main menu and quit the program. You will see a message that says: "Insert system disk and reboot. Pascal users may press \$ and go to command line." Press \$. The familiar command line of Pascal appears. Leave the Quick File program disk in drive 1. Into drive 2 put the Pascal2 or NewPascal2 disk that has the blank file created in step 2.

Step 5: Make An EXEC File

This next step consists of making an EXEC file which will eventually cause the computer to retype all of the data in the newly merged label-style reports back into Quick File. While at the Pascal command line, type M. The computer will prompt you for the name of your new EXEC file. Type:

/QFPROG/MERGE

and press RETURN. In doing so, you are telling Pascal to store the EXEC file on the Quick File Program disk and to call that EXEC file "MERGE." Of course, you can name your EXEC file something else, but you will find it very convenient to store it on the Quick File Program disk. You will then be asked if you wish to change the terminator symbol. Type N for no. (See *Apple /// Pascal: Program Preparation Tools* for a discussion of EXEC files.) The command line now reappears. Type X. When the computer will ask what file it should execute, type:

/QFPROG/SYSTEM.STARTUP.

Be sure to put a period after "STARTUP." Quick File will be loaded and will display the catalog which contains the blank file to be used to store the merged files. Now that you are in Quick File follow its instructions. Type in the number of the blank file and hit RETURN. You will see the message that always informs you when a file is empty and offers to send you directly to the insert records mode. Instead of pressing the space bar, however, press %% in order to terminate the EXEC file. Then hit the space bar.

The EXEC file has been terminated, and you are simply in Quick File. Do not insert any records into the blank file. Simply quit Quick File and press \$ to return to the command line. It is essential to go all the way back to the command line; if you do not do so, your EXEC file will be blank.

Step 6: Add the Label-style Reports to the EXEC File

The next step consists of inserting the label-style reports into the EXEC file created in step 5. Using either Applewriter /// or the editor in Pascal, load into memory the EXEC file from the Quick File Program disk. If the label-style report is

lengthy, the copy feature of the Pascal editor will be unable to hold the entire file at one time. Consequently, I prefer using Applewriter, even though I have Pascal already booted up.

Loaded into memory the EXEC file looks like this:

```
%/QFPROG/SYSTEM.STARTUP.  
6  
%%%
```

where "6" refers to the number of the blank file in the Quick File catalog. Of course, if the blank file has a number other than "6," then the EXEC file will have contain that number.

Immediately after the number of the blank file (in this case, 6), insert a blank line. Without the blank line, part or all of the data in the first category of the first record will be lost. After the blank line and before the "%%%", insert the label-style reports which you wish to merge. Remember, if you wish to sort the newly merged file after it has been written back to Quick File, you must observe the limit of 635 records set by Quick File.

After you have inserted the label-style reports, check through them to make sure that they do not contain extraneous symbols or lines. This process is tedious but necessary. Despite the fact that the reports are written to disk, they are sent as though to a printer and hence contain blank lines to allow the printer to move from page to page. If allowed to remain in the EXEC file, these blank lines will cause information to be written to the wrong categories.

Save the expanded EXEC file onto the Quick File Program disk. If you are using the Pascal editor, be sure to put a period after the name of the file or ".TEXT" will automatically be added.

Step 7: Execute the EXEC File

Get ready to execute the EXEC file, which we have been calling "MERGE." Boot up Quick File. In drive 1 place the Quick File Program disk with the EXEC file stored on it. In drive 2 place the Pascal2 or NewPascal2 disk with the blank Quick File file. Exit Quick File and

go to the Pascal command line by pressing \$.

Once you have gotten to the Pascal command line, press X. The screen will ask "what file?" You type:

EXEC///QFPROG/MERGE

where "/QFPROG/MERGE" is the pathname to the EXEC file. Press RETURN and watch your machine enter the merged data into a new Quick File file. This process is slow. Be prepared to let your computer work 45 minutes or so on long files.

When the computer has finished entering data into Quick File, save the resulting file either on the disk in drive 2 or on an alternate disk. Quit Quick File in the usual manner. This time there is no need to go to the command line of Pascal. 

Disk-of-the-Month

New Releases

DOM #9

Music, Music, Music

Here is a great collection of programs from April through July, 1986. *Music Maker* and *Music Player* let you create and play your own Merry Melodies with alternate sets of DATA statements in BASIC. *Energy Plotter* not only plots energy consumption graphs, but contains techniques to "roll your own." In addition you will find a space game, graphics images and an assembly language subroutine to find maximum and minimum values in an integer array.

DOM #10

Editing Character Sets

A great Pascal program to download and modify or create new fonts, this editor makes child's-play out of designing new text characters to meet your specific needs. Special math signs, foreign alphabets, you can do them all. *Football Pool* is a BASIC program to print out a grid for that office pool. All you do is type in the teams, the scores, and the participants; it does the rest. What? 3-D Video? Yes, indeed, *Stereo Spiral* shows how, using simple Business Basic subroutines. For the more technically inclined, the assembly subroutine *Pixel Inverter* does just that. Also included is *Prompt Procedure*, a collection of Pascal and assembly demos to write to the screen, and a couple of programs in WPL (Word Processing Language) to be used with AppleWriter.

At two for \$12.50 or \$14.95 each, ON THREE's DOM's represent a real convenience bargain, saving the time of typing in programs and offering error-free files. See our order list/price form elsewhere in this issue.

Ram-bo Pascal

dan martin

This article is intended to show the Pascal programmer without a hard disk but with a RAMdisk (either via the 512K Upgrade, /// plus //e card or other means) how to speed up program loading and segment swaps that occur (seemingly endlessly) during a routine Pascal programming session. Since I don't own a hard disk myself, I can't assess whether this is worth doing for those that do.

A Word About File Locations

In the following paragraphs, numerous references are made to the location of various Pascal Codefiles. Rather than exhaustively list all the various possible combinations, I will expect you to follow the general guidance provided and scrutinize for appropriate pathnames. If you have an A143 or a UniDisk ///.5, odds are that you have all the referenced files on a single diskette (if not, then use your PMOVE.code program and do it, silly). If you use the methods suggested in the Pascal Program Preparation Manual for two disk-drive configurations, odds are that most references will be to Newpascal2 in the internal drive and Newpascal3 in your external Disk ///. Pascal 1.1 or 1.2 are assumed in this discussion. Although it should generally work for 1.0, this has not been verified.

Step 1. Deciding Which Programs You Use

In order to get the maximum benefit out of this tip, it pays to stop and think about the elements of the Pascal System that you use most. My choice is the Filer, the Editor and the Compiler. I'm not an assembler guru yet (and may never be). Linking isn't done that often (relative to other functions). Other functions don't require segment swapping or are used very seldomly (eg., library, libmap, etc.)

The one most used is System.Pascal, but I'm afraid I haven't yet figured out a scheme to boot Pascal's interpreter, make a copy of SYSTEM.PASCAL to the RAMdisk, patch the interpreter's System disk reference to the Unit Number of the RAMdisk and then proceed. If and when I sort that one out, I'll update this article. Of course, if your RAMdisk is larger than the conventional 280 blocks of storage, you may be lucky enough not to have to choose at all.

Step 2. Tricking SYSTEM.PASCAL

The basis of this scheme is to make copies of your most used Pascal System elements from the system disk (i.e., the disk where SYSTEM.PASCAL looks for its codefile elements) to the RAMdisk... *before* you select anything from the Pascal command line. The reason for the importance of this sequence is that even when an element of the Pascal System is not present on the disk drive where SYSTEM.PASCAL expects to see it (i.e., the system disk), it will cycle through the on-line devices, examining the directories for the desired codefile. This is exactly the scheme employed for those of you that struggle along with two Disk ///s (take my advice as a former two-disk, get an A143, a Unidisk ///.5 or a hard disk).

Once SYSTEM.PASCAL "finds" the codefile, it remembers where it was found. If you relocate the file after that, it does not go looking again. The names of the various elements of SYSTEM.PASCAL are "hard coded" into the SYSTEM.PASCAL codefile, and it is exactly this fact that we exploit in implementing this scheme.

For the remainder of this article, I am presuming that our objective is to cause SYSTEM.EDITOR, SYSTEM.FILER, SYSTEM.COMPILER and SYSTEM.-SYNTAX to execute from RAMdisk

rather than their normal location on Disk ///s or on another drive serving as the system disk. Apply the same principles for your choice of files.

Boot up your Pascal system normally. When you finally get the Pascal Command Line (i.e., Command: E)dit, R)un, F)ile, C)ompile, L)ink, X)ecute, A)ssem(?), enter X)ecute. Then enter the pathname for SYSTEM.FILER on your disk configuration. Remember that Pascal file input protocol requires you to put a period after the pathname to avoid automatically appending ".code". If your SYSTEM.FILER is on .D3, like mine, the pathname would be: [.D3/SYSTEM.FILER.] This will execute the Filer directly, rather than from the command line. Use the Filer to C)hange the names of the key codefiles to their normal names, stripped of the "SYSTEM." prefix (so you won't forget which is which). For example, SYSTEM.COMPILER should be renamed to COMPILER, and so on.

This change, though quite simple, is enough to baffle the daylights out of our good friend, SYSTEM.PASCAL, when he (or she?) goes to look for those codefiles from the command line. *Remember:* change only the names of those files that you want to execute from the RAMdisk and make sure (by checking the size of the files on a directory listing) that they will in fact fit on the size RAMdisk available to you.

Step 3. Loading Codefiles Into RAMdisk

Q)uit the Filer now, and again select X)ecute from the Pascal Command Line (*Remember:* Don't touch that Pascal Command Line for anything other than X)ecute until the end of this entire procedure.) This time we want to use the editor (whose name we just changed to EDITOR as opposed to SYSTEM.EDITOR).

Therefore, enter the pathname for EDITOR. on your particular disk configuration.

When the editor comes up, if you have a malingering SYSTEM.WRK.-TEXT file lurking from a previous session, you'll need to Q)uit and then C)hange to another file. Now hit return for "no file." Then S)et E)nvironment A)scii True [Ctrl-C] to switch from the normal "Pascal textfile" mode into "Ascii file" mode, because what you're going to do next is to construct an EXEC file that will copy the needed files from where they normally reside to the RAMdisk before every Pascal session.

Using the I)nsert command of the Editor, enter the following lines carefully:

```
%x.D3/filer.  
t.D3/filer  
.ram/system.filer  
t.D3/compiler  
.ram/system.compiler  
t.D3/editor  
.ram/system.editor  
t.D3/syntax  
.ram/system.syntax  
q%%%%%
```

In the above EXEC file, use the appropriate pathname for the location of your files.

Now [Ctrl-C] to end the Insert, Q)uit and W)rite to *transfer. (again the period prevents ".text" from being appended). (* implies the system disk device/volumename.) Then E)xit to the Command Line. Now select X)ecute again. This time respond with: exec/*transfer., sit back and watch your files be "magically" transferred to the RAMdisk. From now on, when you select the editor, filer or compiler from the Pascal Command Line, they will snap immediately into action, as opposed to the normal, drudging disk whirring for an eternity (so it seems) before the selected function's command line appears.

Incidentally, the above EXEC file can also be constructed using the M)ake exec function from the Pascal Command Line. Consult the Pascal Manuals for its use. The above scheme, however, allows you to edit the keystrokes without actually having to wait for the result of their execution (great if you type with ten thumbs like me.)

NOTE: For a very interesting variation on the theme, instead of using the normal SYSTEM.FILER, replace it with the file named, SYSTEM.STARTUP from the System Utilities Disk. This way, when you select F)iler from the Pascal Command Line, up snaps System Utilities. (Thanks to Dennis Cohen for this idea.) This is especially great if you don't use the workfiles for editing and compiling. If you do, you'll tend to still use the Filer. From now on, when you boot up your Pascal System, the *very first* thing you should do is to X)ecute exec/*transfer. and wait for the file transfers to complete before using the functions from the Command Line. This is a good candidate for a keyboard macro for either Power Keys or *Macro Manager*™.

Other Variations on the Theme

There are bolder things that can be done to customize your Pascal configuration that involve using the Disk Block Editor to go in and patch file references within the editor, compiler, etc. We'll leave these for another time. In the meantime, keep on coding, ///ers, since that is the only key to new software for our beloved SARA. 

ON THREE Presents...

Grafix Manager™ \$49.95 plus \$3.00 s/h

The complete graphics utility for the Apple /// interfaces to Draw ON ///™ and all graphics programs and allows printing enlarged or reduced portions of the graphics screen, normal or inverted, single or double density and with four rotation values.

For the first time you can load directly any DOS 3.3 or ProDos Hires or double Hires graphic files (including "Print Shop") and of course SOS fotofiles or other binary graphic images.

Comes complete with full documentation and diskette containing standalone SOS interpreter and a Desktop Manager™ module. All popular printers, serial and parallel interfaces supported and limited color graphics capability is included.

• Available now!

One, Two, /// Forum

VisiPhone

Dear Sir:

We enjoy your magazine very much. We have a phone number and name that might help your inquiry about Advanced VisiCalc. We needed a new program diskette as we kept getting I/O errors and couldn't exit the program. It took a year and a half and a lot of shuffling around. We went from Paladin to Software Arts and finally to Lotus Development for technical assistance. We talked to actual people and finally received a program. The phone number is 617-253-9150. Hope this helps.

Sandia L. Johnson
Minneapolis, MN

Perhaps there is still hope for VisiCalc and Advanced VisiCalc users. Yours is the second letter we have published in as many months which furnished a telephone number for Lotus. (The number given last month was (617) 577-8500, and Lotus is located at 55 Cambridge Parkway, Cambridge, MA 02142. In this time of diminishing support it is always an "upper" to receive a letter such as yours.

IDS Ideas

Dear Bob:

I acquired an IDS #460 printer with my Apple /// and have tried to get it up and running off of the RS-232 serial port. It prints ok, but not as the text.

Nothing in the IDS #460 manual tells me the dip switch settings for the Apple ///. Since you have had one, can you give me a few pointers?

Does *ON THREE* have a buffer or program delay for being able to use keyboard for input while the printer is running?

C. E. Plummer
Menlo Park, CA

Essentially there is no difference in the way you would set the dip switches on your 460 for an Apple][or an Apple ///. What must be done, however, is to determine that printer parameters, as specified by the dip switch settings, agree with the parameters shown in the RS232 driver configuration block. To do this, you should refer to the Standard Device Drivers Manual, commencing with page 118 and then, using the System Utilities System Configuration Program, reconfigure your driver for the IDS.

In a limited way, while running Business Basic, you can halt program execution (while the printer is on) with strategically placed INPUT statements in the BASIC program. With the appropriate BASIC commands, the text that is input from the keyboard may be directed to either the console or the printer before program execution resumes. It is also possible to accomplish the same thing from AppleWriter by writing a WPL (Word Processing Language) program to suit your needs. In addition, since our Desktop Manager allows the interruption of any program at any time, it is possible that its print command could be used for your purpose.

Goto VisiCalc

Gentlepersons:

I am interested in finding a solution to a problem if there is one. I use VisiCalc for spreadsheet work and use almost 200 lines for my stock analysis. Has anyone worked out a "GOTO" or "FIND" within VisiCalc to rapidly find a line name rather than pressing the "DOWN" scroll key. An example would be "FIND" General Motors. This would be a great aid if it can be done.

Robert H. Garrett M.D.
Toledo, OH

Well, we don't know of a specific "FIND" function written for VisiCalc, although we agree the concept would be most useful. However, your letter implies that you are not aware of the powerful "GOTO" function in VisiCalc and most other major spreadsheets which should certainly expedite moving directly from one cell to another, rather than using the cursor move keys. The command key is the less-than sign [$<$], followed by the cell number you wish to go to. For example to return to the top left corner of your model, type ">A1" and you will move to cell A1. Similarly, if you wish to move from the beginning of the spreadsheet to another location, even if you don't know the specific destination cell number you can estimate by typing, for example, ">S75" and then use the cursor keys to locate the precise cell desired.

Wild Thoughts

Dear Bob:

I just installed the *Disk Manager* module to the *Desktop Manager* and like it. However the absence of the "wild card," especially in the "Copy-File" mode, makes it a good tool, not a great one. The added facility of the wild card should really be considered. In normal use, one has to go back to the System Utilities mode without that power.

J. K. Fontenot
San Jose, CA

When Rob was first designing Disk Manager, the consideration of including a wild card was discussed. However, unlike System Utilities, Disk Manager is a "background" type of program which greatly complicated the process of writing in a wild card feature. Nevertheless, a forthcoming revision (date unknown) of Disk Manager will, at the very least, include a file selection menu and perhaps a wild card as well. Our primary interest was in making the Disk Manager module available at the earliest possible moment, so as to be able to offer Desktop Manager users a maximum amount of flexibility. Now that this has been done, time will be devoted to enhancing both the main module and the optional modules. For example, Macro Manager will be upgraded to add the ability to chain one MacroMap to another, making possible macros of virtually infinite length. The next Desktop Manager module to be released will be Bob's Spell Manager.

Spacing Out

Dear Val:

The following is an excerpt of a letter received from a former Space Coast Systems employee who has authorized its use:

"Effective Aug 1, 1986, SCSUG (short for Space Coast Systems User Group) will begin accepting members and attempting to resolve reasonable support and repair problems occurring with Space Coast Systems equipment. This group initially will be comprised of ex-employees that do not believe that events occurring within Space Coast should affect customers that still need support. Unfortunately we cannot honor any outstanding warranties but will repair equipment at a reasonable cost for parts and labor. If you have any questions about this group, or any problems with your equipment that you would like to have resolved, please contact us at the following address:

SCSUG
P.O. Drawer 2767
Titusville, FL 32781

At this time there is no phone available but we will soon be on CompuServe for user convenience. When writing, please include mailing and shipping address, daytime and nighttime phone number if possible."

I would also like offer my services as a link for non-CompuServe Bulletin Boards and would like to help in getting everyone in touch with each other as well as the SCSUG. I have a lot of experience with this system. Unlike the SCS former employees, I can make a phone number available if needed since I have no ties with SCS that would result in the irate calls they have received. Apple][users who have this same equipment should contact me also.

Mike Schroeder
New Brighton, MN

ON THREE will serve as a "switchboard" for you and route appropriate questions and requests for information to you.

BASIC is Variable

Dear Mr. Consorti:

I have been a subscriber to *ON THREE* for several years and enjoy your publication. I have made use of several tips that have been suggested, especially concerning Business Basic.

I am writing because I have a recurring problem in a Business Basic program that is haunting me. To properly describe the problem, I have included a partial listing of both the "before" and "after" situations. Please refer to these listings.

First, to describe the environment: I have an Apple /// which originally came with 128K and was upgraded to 256K by my dealer. When the program is executed to the point that the arrays are loaded, the PRINT FRE command returns 82667.

I have made several changes to this program over the past months and every time I make a change to the array definition area I get a VARIABLE ERROR—this of course is a trial-and-error system and I am never sure if I will be able to eliminate the error. I have been successful in the past, but I am also concerned about future improvements that are planned.

I have enclosed two listings of part of the program. The first one works properly. The second listing returns a VARIABLE ERROR. I know from experience that had I changed the order of these arrays in any way, I would have gotten a variable error someplace.

Can you possibly help me to eliminate this problem? It has caused a great deal of grief and I am very concerned about future changes.

Howard L. Olien
Waseca, MN

We are unable to reach any conclusions by just looking at your listings. If you would like us to explore further, you should send us a disk containing copies of both programs, along with the version of Business Basic that you are using. One possibility that occurs to us is that version 1.23 of Business Basic allocates array space differently from version 1.2 and makes more memory available to the program. It is also possible that, with the changes you have made, you are attempting to allocate more array space than is available in a 256K machine. If you have more than one version of BASIC, or a friend with a 512K machine, try and check out different configurations as much as possible, and failing that send us a diskette as we mentioned above.

Female Mail

Dear ON THREE:

Although 80% of what appears in *ON THREE* is over my head, I thoroughly enjoy reading it, and feel it serves a very real need. Everything I know about the computer, I've learned out of a manual or a book. I live in a small town and getting to a user's group is well nigh impossible. But the Hot-line number for help has been great. I've used it only once, but in less than 30 minutes I learned a great deal and had the Keystroke Data Base running on my Qume Sprint 5.

What is a doddering 65-year old woman doing with all this equipment? Well, I began with a discarded Apple][plus from my brother's office. When he updated to ///'s he bought me one, too. (My son is now using the][plus in his business.) I have a specialized horticultural business in herb plants, both wholesale and retail, and in addition a small retail shop, the Herb Market. We publish a catalog and at the present time have some 16,000 on our mailing list. I use the Three for everything from word processing to writing payroll checks. I have only three programs, AppleWriter, Advanced VisiCalc and Keystroke Data Base.

I would like a good mail list program. Many of our names were laboriously entered using Apple Post on the][. We do emulate this, but need a program just for mailing lists. Keystroke has proved helpful for small lists, wholesale, sources, etc., but as a direct marketing mail list leaves something to be desired. What do you suggest?

Those who are writing programs should consider small programs for specific requirements. Sometimes programmers get carried away by all the things they can do and cram too much into one package. This is discouraging to those of us who have only an elementary grasp of the computer. I'd like to be able to buy a check writing program, another for inventory, and one for my mailing list for \$60 or \$70 each, rather than a great grandiose program that will do *everything* at \$175. I probably would have bought four or five such small units long ago, rather than devising my own or weighing the merits of do everything programs. A lot of people would consider small, specific, easy up, easy to learn programs [that are] very user-friendly.

Mary Wetzell Peddie
Washington, KY

We learn as we go, and we are currently learning that with the numbers of Apple ///'s changing hands these days, there are more and more users who are not acquainted with computing or computers. Accordingly, we are adjusting the content balance in ON THREE to more accurately reflect this trend, and are attempting to run more articles aimed at the layman. Please let us know how you feel we are doing in this respect. We would like to suggest you contact the Third Apple Users (see the user group listings in this issue) as a group that may be able to help you. They are not terribly local in nature. See also RANNTINGS in this issue.

The only problem with programs that "do it all" is how well they do it. One of the many advantages in this type of program is the common user interface, where the same set of commands functions near-identically in each of its modules. You should check the February 1986 ON THREE for reviews of Apple's Mail List Manager and CompuCraft's Post Master.

RFI Problem Solved, FYI

Dear Bob:

I recently encountered an "Unable to save to .d3" error using /// E-Z Pieces when attempting to save a /// E-Z Pieces file to my A-173 MicroSci disk drive. Using System Utilities I copied all files from the disk in .D3 to .Profile so that I could "verify" the disk in .D3. I ran the "verify" function in System Utilities on the disk in .D3 and a list of bad blocks resulted. I decided to try and re-format the disk in .D3 using System Utilities. System Utilities refused to format the disk, informing me that there was a "Device Dependent Error #34—refer to the Manufacturer." I began researching for information I seemed to recall [see "Taming Timing," ON THREE, April, 1986 . . .ed] about readjusting the speed of the A173, thinking perhaps that was my problem. While

looking, I noted a reference to RFI [Radio Frequency Interference] from RGB color monitors affecting disk drives. As it happens, my A173 sets adjacent to my Panasonic RGB color monitor. So I moved the A173 about ten inches away and placed a three-ring binder between the monitor and the A173. Upon re-trying the "save" function of /// E-Z Pieces it worked perfectly. So did the format function of System Utilities. Thus the lesson is that an additional reason for the "Device Dependent Error #34" can be RFI from color monitors. Thought the readers of ON THREE might profit from my experience.

While I am writing, I wanted to let you know that I maintain a Legal Information BBS, 24 hours a day, seven days a week, 300/1200 baud, seven bits and no parity, using "Let's Talk," an Apple /// and an A173. The board contains current topics on California law on wills, estate planning, personal injury, trusts, joint tenancy, community property, probate, drunk driving, child support, legal humor, bulletins, and an electronic mail facility. It is open to the public and also provides a means for clients to conduct their legal affairs electronically with my office. The board can be accessed Monday through Fridays from 8 am to 6 pm at (916) 872-8342. From 6 pm to 8 am weekdays, holidays and weekends, the board can be accessed at (916) 894-0709.

Jack D. Wood
Chico, CA

RFI is not limited to RGB monitors and in fact we have seen problems with the internal drive when a green-screen monitor is used as a replacement for a Monitor /// and is placed in the usual position on top of the Apple ///. Sometimes a sheet of aluminum or lead foil used as a shield can eliminate the RFI without relocating equipment.

ON THREE Presents . . .

Reconditioned 512K Apple ///'s with Monitor ///

Available Now!

New Low Price \$1148

256K Apple /// and Monitor \$749

- for yourself
- for your office
- for a friend
- for a business associate

plus: \$50 shipping and handling

OF COURSE!

**Backed by ON THREE's
limited 60-day warranty**

Only ON THREE sells 512K Apple ///'s—the world's finest microcomputer. ON THREE provides complete support at no extra cost, plus a full line of ON THREE peripherals and sophisticated software.

Help Wanted

Dear Bob:

Great to have you back with the magazine. We are avid readers and need all the help we can get. Presently we have three Apple ///s with ProFiles and monitors. All are busy. I have some questions and comments.

- 1) No one seems to [be able to] tell us the proper maintenance for disk drives. We are able to correct speeds and clean heads, but how about the inside? Do they need lubrication on the shafts and the spiral? Ours work better if cleaned yearly and a drop of light machine oil is added—but is this proper?
- 2) Someone recently asked about hooking up an IBM typewriter to an Apple ///. No idea about IBM, but we recently hooked our Xerox 6010 Memory writer to our /// and it works great. Xerox has a kit with an interface module and modem eliminator—works off the RS232 port, so no precious slots are used. By changing baud rate, line feed and one or two other details, we were up and running in about two hours.
- 3) Your comments about Catalyst and PFS:File are correct. "File" cannot be installed under Catalyst, even though both companies say it can. PFS went so far as to send me a completely new kit (free) with the latest version, indicating it would install under Catalyst. No soap. If anyone has a way, it would be most appreciated. (We know about Selector, but are not ready to make the big change yet.)
- 4) We purchased Haba's Graph 'n' Calc even though we had heard it would only print to a DMP or Epson MX-80. We have an Okidata 83A and we thought we would be able to work it out, but so far—no luck. Can anyone help us get this program printing graphs to our Oki—please? We can go through the RS-232, a UPIC or a Pkaso/U.
- 5) We would like to be able to use our Oki 83A for letter quality. The unit knows how to double strike in the BOLD mode, but this gives a large type face. Does anyone know how to fool it to double strike in the regular size typeface? I realize the 93 model will do this, but I like my old 83A.
- 6) Also, we need a better underline procedure for the Oki when using AppleWriter ///. It is easy with Word Juggler, but a real bear for AppleWriter. Does not seem to want to use the reverse slash (\) technique.
- 7) For making archival copies we have been very successful using Apple][emulation and Copy][4.4D with synchronization. Does a fine job for most of our standard programs such as Advanced VisiCalc, Data Base ///, AppleWriter ///, Lexicheck and all PFS programs. Word Juggler copies better with Locksmith.

Finally, a cheap fan from Radio Shack is a real plus when blowing up through a hole in the desk, directly on the metal plate on the bottom of our units. Practically a necessity as our slots get filled.

Bob, keep up the good work—incidentally we belong to both the North Jersey and TAU users groups.

Eric A. Sheard
Flemington, NJ

Well, Eric, you have certainly opened up a number of interesting topics for discussion. We don't expect to be able to answer them all, but where we fall short, we ask our readers to fill in.

As far as disk drive maintenance is concerned, we can only pass on our own experience with two Apple][drives, one, an original Disk][is approaching eight years of age, and the other, a MicroSci is at least five years old. Other than

a rare cleaning and frequent drive speed adjustments, we have performed no maintenance whatsoever. We had to replace one chip on the analog board of the Disk][, otherwise both drives have been failure-free. It doesn't appear that an occasional drop of oil would do any harm, although we have never felt the need. If the drives are oiled, extreme caution must be used to ensure that the oil does not spread from its intended area and contaminate otherwise oil-free areas.

Presumably any electric typewriter with an RS-232 interface can be hooked up to an Apple /// or other computer. The kicker is that most electric typewriters are not designed to handle the severe duty that would be posed by computer service, printing program listings, etc., and therefore it may be anticipated that a higher than normal mechanical failure rate would be a consequence. Secondly, most electric typewriters, like letter quality printers, are very slow. Thirdly, such a printer would be considered non-standard, and many applications programs make no provisions for other than the usual group of Epson, DMP, ImageWriter, etc. printer control codes, thus problems could be encountered in this area. Within these constraints, an electric typewriter that can serve the dual purposes of its original function and the supplemental function of a computer printer might be worth considering.

Actually, our comments about PFS:File were incorrect, as we later discovered, since we are now aware of cases where it runs under both Catalyst and Selector. The procedure to install it, however, we will ask our readers for help with.

A number of applications programs consider the Okidata printers as non-standard and thus do not provide printer control codes. It is probably possible, by comparing and modifying control codes, and telling Graph 'n' Calc you have a DMP, etc., to use the Oki, but it seems to us that a more workable solution is to save the Haba files to disk and print them out using our Grafix Manager, which is equipped to handle virtually every graphics file type and printer configuration conceivable.

While we do not have Okidata manuals available to us, we suspect there is a way to get the 83A to overstrike as you desire. It would seem to us to be merely a matter of experimentation to find the proper combination of printer codes to do what you want. Just about every printer around will allow the mixing of control codes for different effects. If we were faced with this problem, we would write a short BASIC program to test various printer code strings until we found one that would work.

As for the underline problem we have no ideas, but it certainly should be resolvable. Maybe this is one which Sharon Webb or our readers can help you with.



DE CLASSIFIEDS

Classified rates: \$1 per word, \$25 minimum. Copy must reach us 60 days prior to cover date, e.g., November 1st for January issue, which would be mailed December 1st.

Subscriber Discounts: .50 per word, \$12.50 minimum, subject to the following restrictions:
• Non-commercial ads only • No items valued over \$100

FOR SALE: Apple /// 256K with Monitor /// and MicroSci A73 drive. Software: Word Juggler, PFS File, BASIC, Pascal. Steve (203) 228-0362 evenings.

FOR SALE: Apple /// 256K ProFile hard disk with Catalyst, two floppy drives, Pkaso, Okidata Graphics card, 3 E-Z Pieces, PFS File-Report, AppleWriter, Pascal plus library, all manuals. Make offer. Bob (415) 325-4918.

FOR SALE: 2-512K Apple ///s, 1-256K Apple ///, 2-Monitor ///s, 1-Corvus 6Meg H.D., 1-Corvus 10Meg H.D., 3-Corvus Apple /// slot cards, 1-Corvus Multiplexer, 2-Corvus OmniServers, 1-Corvus ext. mirror, 1-Corvus int. mirror, 2-Corvus tap boxes, 1-Corvus A drive Tech Manual, 1-Corvus H drive Tech Manual, 1-Apple // Corvus System Manual, 1-IBM Corvus System Manual, 1-Apple /// Level II Service Manual, 1-Apple /// 256K Memory Board, 1-Corvus OmniNet 10Meg H.D with Mac cable and software. Large assortment Apple /// software and other misc. hardware. Call 24 hours, US: 1-800-252-5512, Oregon: 1-800-525-5512.

WANTED: Your de-classified ad. It could bring you cash for surplus equipment or programs. Send ad copy with check to ON THREE De Classifieds, P.O. Box 3825, Ventura, CA 93006.

Rantings

richard/lavona rann

We have a confession to make. We own an Apple ///, and we are proud of it. Not that we had any idea just what it would mean when we bought our /// some five plus years ago, but that was the beginning of a lot more than what one could expect from purchasing a computer. What we purchased was the first microcomputer that had most of the functions and features that we felt were necessary to be an effective business machine. The /// purchase also led us into something totally unexpected and worth quite as much to us. What we, and many other /// purchasers didn't foresee was a whole new world of interesting and fulfilling personal and business relationships.

Fortune and the Wall Street Journal periodically refer to the concept of an "Old Boy Network." Although Hollywood has romanticized the concept into a single purpose "brown nosing" way to "get ahead," it traditionally referred to the synergy developed when successful businessmen from varying fields exchanged ideas. Those of you who have gotten involved with an Apple /// user group have an idea of the bond formed between Apple /// owners all over the world. As officers of a Apple /// user group, we have had the opportunity to get to know some very interesting people—all of them Apple /// owners and users. What many of you may not know is what that can translate to in terms of your business or professional goals.

The image of a /// owner can be tall or short, fat or thin, but all are intelligent people. Many are business people using their Apple ///s to manage a wide variety of businesses. Some /// people are educators working in school systems or universities while others use ///s for research and support of technical and professional endeavors. What all of the owners/users have in common is that they are goal oriented and intelligent. They each have at least one good reason for using their Apple ///, and are moving towards specific goals. Watch out for the typical Apple /// owner because you

will have to run to keep up.

Not inconsistent with the above is the fact that a large portion of the /// community are avid readers of professional and technical materials. What appears odd is the fact that most also read science-fiction. What that has to do with the computer, we have no idea, but it seems to indicate a person who is interested in expanding his horizons. (Sharon Webb, who has written several articles for *ON THREE* is also a successful science-fiction writer.)

When you speak to another /// owner, you know that you are probably talking to someone who carefully researches their needs and then makes a commitment to a direction. People didn't buy Apple ///s because it was "the thing to do" or because of a big advertising campaign. Neither have they succumbed to the wild claims of later machines or the pressure to think blue. Of course, they will eventually move on to new technology. But it will be the result of a rational, well-thought out analysis rather than an emotional move.

What does all this mean for your business or personal goals? First, it probably makes you proud to be a /// owner. More importantly it opens several doors of opportunity for you. We used the word synergy in our definition of the positive view of the "Old Boy Network." Synergy is defined as the simultaneous action of separate agencies resulting in a greater total effect than the sum of their individual effects. Think again of the /// community and its large number of educated, thinking, intelligent people and its close knit bonds. Can such a group be less capable of developing new solutions to problems and new ideas than a group of MBA's? Don't get us wrong, we have nothing against MBA's. We worked hard for one, but our community represents a much wider range of training and skills.

Getting active in the /// community is quite easy to do. It can start as simply as writing away for informa-

tion on user groups, sending your name in as a Hot Line volunteer for *ON THREE* or a user group, taking a stand on a controversial issue and writing it up for publication, or just calling someone for help. Many people have first gotten active when needing help with an Apple /// problem and turning to a volunteer or user group for help.

Most of the very active people in the community started out by needing help and then deciding to repay the community by helping others with similar or other /// problems. (So-called novice computer types can make very good volunteers when it comes to assisting people that are a little newer at the process than they are.) Once the interaction starts, it grows naturally into professional and personal relationships and often friendships.

The bottom line of all this is that you are missing out on a great opportunity if you have not yet gotten involved, at least thru correspondence, with the /// community. Many of you have noticed that the *One, Two, /// Forum* letters column has lots of useful information in it. Some of you have certainly called some of the Hot Line numbers for help. But all of you should look at the list of Apple /// User Groups and join at least one.

Most of the groups are relatively small and represent a local geographic area. These are very worthwhile for general information exchange and emergency assistance. There are three groups that are quite large (ATUNC which is listed under California, TAU listed under Illinois, and ATGI listed under Overseas) and have close connections to /// community and large, regular newsletters. Since even the relatively low costs of most of the user groups would add up quickly if you were to join several, we suggest that you look into a local group, if there is one nearby, and one of the three larger groups. Most will gladly send you information and a free issue of their newsletter. Whatever you do, get involved. You will not regret it.



How many dollars have you invested in your Apple /// ?

Answer this questionnaire and find out how to extend your computer's life:

- Do you vacuum your office or home less than twice a day? YES NO
- Are there smokers in your office or household? YES NO
- Are there children in your household? YES NO
- Is the computer located in a family room or other high traffic area? YES NO

If you answered "yes" to one or more of the above questions, then you need to protect your investment with an *ON THREE* Dust Cover.

**Dust Cover for Apple /// and
Monitor ///
\$11.95**

**Dust Cover for Profile,
Apple /// and Monitor ///
\$12.95**

Plus \$2 Shipping and Handling each

ON THREE (805) 644-3514

P.O. Box 3825
Ventura, CA 93006

Send me _____ Apple /// dust covers

Send me _____ Apple ///-Profile dust covers

Name _____

Address _____

City _____

State _____ Zip _____ Phone _____

enclosed \$ _____

M/C Visa AE*

number _____ exp. date _____

Signature _____

*3% surcharge on American Express. California residents add 6% sales tax.

ON THREE Presents...

I ♥ My Apple /// T-Shirt Bonanza!

- A bright array of colors for simmering sunny days
 - yellow
 - blue
 - white
 - beige

\$11.95 plus \$3 s/h
- Maintain your bod like your ///
I ♥ My /// Sweat Shirts
 - yellow
 - blue
 - white
 - silver

\$18.95 plus \$3 s/h

sm med lg x-lg
- Cap it off with I ♥ My /// Caps
\$5.95 plus \$2 s/h

Draw ON ///™

from ON THREE

**The most versatile Apple ///
graphics tool ever designed!**

\$179 ... plus \$5 shipping and handling

- Spruce up dull graphs
- Create new fonts, drawings
- Cut and paste
- Shrink, rotate, invert images
- Print graphics screens to most popular printers

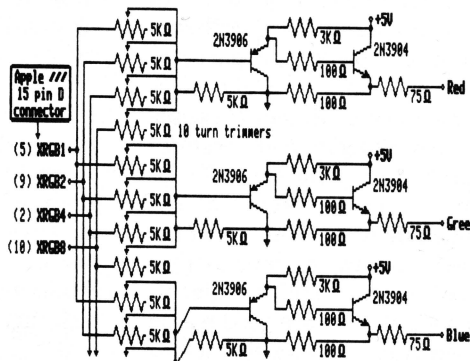

Using Catalyst

j. donald glenn

Those of you who are using Quark's Catalyst program selector have already found what a great tool it can be. No more booting each application when you need it. To move from AppleWriter to VisiCalc, all you have to do is press both apple keys and escape and you are immediately back to the Catalyst menu. Most programs (even copy protected ones) will load onto Catalyst, saving you from wearing out those precious copy protected disks. And combined with Quark's Discourse spooler, it really makes working with the Apple /// great. You can print an AppleWriter report to Discourse and, while it is printing, go to VisiCalc and be working with that program. No more waiting several minutes for a report to print.

Catalyst 2.0 (2.1 is the current version) will allow you to load up to 48 programs on the Catalyst menu. If that is not enough, Quark provides for both BASIC and Pascal language menus. At the Catalyst menu level, you have one entry for loading the BASIC system and one for loading the Pascal system. When you select either language from the Catalyst menu, you see a language menu of programs which can be run from that particular language. When a language menu is first accessed, it will contain one entry called the BASIC (or Pascal) Menu Editor. You can use this editor to load program names which can later be run by just entering the appropriate number from the language menu.

Let's assume that you have written a terrific program to sort VisiCalc files. Your first program is called HELLO. It calls PROG1 which calls PROG2. Now you want to put them onto the Profile and run them from the BASIC language menu. From the Catalyst menu, select BASIC and the language menu will come up. Enter the appropriate menu number for the BASIC menu editor. Three items are requested by the language

menu editor. The first asks for the display name for the program. This is the name which will appear on the language menu when you first enter it. You could use the name of Visisort for the program. The second entry is the prefix to be set before the program is executed. Often, Business Basic programs are not written to optimize the use of the Apple /// directory structure and the Profile hard disk and this feature is quite beneficial. You can simply set the prefix from the Catalyst language menu editor. When you only have a compiled Pascal program and are not able to change the code, this feature would allow you to place the code within a subdirectory rather than the root directory. The third item asks for the program path of the program to be run. In our example, the program path could be .PROFILE/BASIC.PROGS/VISISORT.

The next step would be to copy the BASIC programs to the directory. For instance, you would copy HELLO, PROG1 and PROG2 to .PROFILE/BASIC.PROGS. Then from the Catalyst menu select the number corresponding to the BASIC language. You will get the momentary BASIC title and familiar beep followed by the BASIC language menu. It will have your Visisort program listed. By selecting the number for that program, it will automatically be run. You don't have to remember the directory where you placed the programs or what you called them.

The programs which build the language menus are called BMENU.EDIT and PMENU.EDIT for BASIC and Pascal respectively. Each one creates and updates a file of menu names. They are automatically loaded when you initially load Catalyst, but can be copied to .PROFILE/CATALYST if you have inadvertently erased them. The BASIC version is BASIC.HELLOS and resides under .PROFILE/CATALYST while the Pascal version is called PASCAL.STARTS and will be in the

root directory.

But suppose that you really want your VISISORT program to be called from the Catalyst menu rather than having to remember that it is in BASIC. Catalyst allows this. Catalyst provides excellent instructions for loading any BASIC or Pascal program into the Catalyst menu. When the program finishes executing, it simply dumps you back into the language prompt. The user then has to press both apple keys and the escape to return to the Catalyst menu.

One of the things you might want to do with your BASIC or Pascal program is to exit directly back to the Catalyst menu rather than the language prompt. Some commercial programs can be loaded onto Catalyst to do this. For example, VisiCalc and AppleWriter. However, Quickfile will not. For programs you write yourself or have access to the source code, Quark provides an assembly routine to return automatically to the Catalyst menu. They have not documented this feature; I assume this is because most programs put onto Catalyst are purchased and the user is unable to modify the code. Some firms are selling programs written in Business Basic such as Data Manager III. Other programs are in the public domain and the source code for them is available. Programs in these categories should be easy to change. Still others among us may wish to write their own applications which can be called from the Catalyst menu.

The assembly routine which will transfer you directly back to the Catalyst menu resides in the file CATALYST.UTIL which you will find under .PROFILE/CATALYST. This is an interesting little routine and can really professionalize your own programs. You can easily write an exit routine in either BASIC or Pascal to use this routine.

(Cont'd on page 32)

Call Three: Hot Line/Apple /// User Groups

If you would like to get together with other Apple /// owners and exchange ideas, a user group is for you. Below is a listing of all Apple /// user groups known to us. If you have recently formed a group or know of one we have not listed here, please contact *ON THREE* and let us know so that they may be included. There is no charge for this service.

California

Sacramento Apple /// User Group
1433 Elsdon Circle, Carmichael, CA 95608
(916) 482-6660

Orange County Apple /// User Group
22501 Eloise Ave., El Toro, CA 92630
(714) 951-1231

L.A.-So. Bay Apple /// Users Group
P.O. Box 432, Redondo Beach, CA 90277
(213) 316-7738

Apple /// Users of Northern California
220 Redwood Highway #184
Mill Valley, CA 94941

International Apple Core Apple /// S.I.G.
908 George Street, Santa Clara, CA 95054
(408) 727-7652

Canada

Apples British Columbia Computer Society
Apple /// S.I.G.
P.O. Box 80569, Burnaby, BC
Canada V5H3X9
(416) 839-7779

Canadian Apple /// Users Group
80 Antibes Dr. Suite 2805
Willowdale, Ontario, Canada M2S9 3N5
(416) 665-3622

The Astronich Club

1453 Highbush Trail, Pickering, Ont.
Canada L1V1N6 (416) 839-7779

Colorado

Colorado Apple Three User Group
P.O. Box 3155, Englewood, CO 80112
(203) 226-4128

Connecticut

Apple /// Society of So. Connecticut
34 Burr School Rd., Westport, CT 06880
(203) 226-4128

Florida

Sarasota Apple /// User Group
c/o Computer Centre
909 S. Tamiami Trail, Nokomis, FL 33555
(813) 484-0421

Georgia

Atlanta /// Society
385 Saddle Lake Drive, Roswell, GA 30076
(404) 992-3130

Illinois

Third Apple Users c/o Lavona Rann
1113 Wheaton Oaks Dr., Wheaton IL 60187

Kansas

Kansas City Apple /// User Group
5533 Granada, Roeland Park, KS 66205
(913) 262-3355

Maine

So. Maine Apple Users Group
Casco St., Freeport ME 04033
(207) 865-4761, X 2249

Maryland

Apple /// SIG Chairman
Washington Apple Pi
8227 Woodmont Av. #201
Bethesda, MD 20814 (301) 654-8060

Minnesota

Minnesota Apple Corp Users Group
P.O. Box 796, Hopkins, MN 55343

New Jersey

North Jersey Apple /// Users Group
c/o Roger T. Richardson
P.O. Box 251, Allamuchy, NJ 07820
(201) 852-7710

North Carolina

North Carolina Apple /// User Group
2609 North Duke St. #103
Durham, NC 27704

Ohio

Cincinnati Apple /// User Group
5242 Horizonvue Drive
Cincinnati, OH 45239
(513) 542-7146

Apple Dayton - Apple /// S.I.G.
P.O. Box 1666, Fairborn, OH 45324-7666
(513) 879-5895

Oregon

Oregon Apple /// Users Group
1001 SW 5th Av. #2000
Portland OR 97204
(503) 645-6789

Overseas

Apple THREE Group International
c/o Maj. H. Joseph Dobrowski
P.O. Box 913, Langley AFB, VA 23665

Apple /// Users Belgium/Netherlands
c/o H. Van der Straeten, Vestinglaan 49
2580 Sint-Katelijne-Waver, Belgium
(015) 205328

Apple User Group Europe e.V.
Box 11 01 69 D-4200, Oberhausen 11,
West Germany 0049-6195-7 3917

Apple /// User Group Belgium/Netherlands
c/o J. Woretshofer, Ganzenkweerd 22,
NL-6229 TG Maastricht, The Netherlands
(043) 611704

British Apple Systems User Group (BASUG)
Apple /// S.I.G., P.O. Box 174,
Watford Herts, England WD2 6NF
0727 73390/72728

Le Club Apple
43 Avenue de la Grande-Armee
75116 Paris, France

Apple /// User Group
c/o Canberra Accounting Services
P.O. Box 42
Duffy A.C.T. 2611
Australia

Texas

Apple Corps of Dallas
Apple /// SIG
P.O. Box 5537
Richardson, TX 75080

River City Apple Corps /// S.I.G.
Box 13349, Austin, TX 78711
(512) 454-9962

Houston Area Apple Users Group
(Apple /// Division)
P.O. Box 610150
Houston, TX 77063
(713) 480-5690 or 974-5153

Virginia

Charlottesville Apple /// User Group
216 Turkey Ridge Rd.,
Charlottesville, VA 22901
(804) 642-5655

Greater Tidewater
Apple /// User Group
Route 2, Box 216
Hayes, VA 23072
(804) 642-5655 or
898-3500, ext. 2671

The *Call Three: Hot Line* is a service whereby Apple /// users with problems can call an area number to get assistance. The individuals answering the phones are fellow Apple /// users who have volunteered to help others over some of the rough spots. They are not compensated for this service, therefore we owe them a resounding "three cheers."

We would like to expand this service even further, so if you are familiar enough with your machine to be able to aid others and answer questions, please write us, stating your areas of expertise and availability in terms of days and hours. Certainly you can bask in the knowledge that you have been able to help a fellow Apple /// user.

For those of you who have questions, feel free to call our consultants listed below. **Please** observe however, the calling hours shown and before placing a call, double check the time zone so that you don't inadvertently wake someone up! There are no other restrictions on using the service other than as stated above. Again, **please** remember these people are volunteers, and if we receive information indicating that calling hours are not being observed, we will have no choice but to remove the consultant from the listing or, worse, discontinue the service.

The following is an alphabetical listing of subjects and abbreviations used in the "subjects" column of the consultants listing.

Subject	code	Subject	code
Accounting	AC	Graphics	GR
Agriculture	AG	Micro-Sci	MI
Assembly Lang.	AL	Modems	MD
Business Basic	BB	Modula-2	MU
Catalyst	CT	Pascal	PA
Cobol	CO	ProFile	PR
CP/M	CP	Quark	QU
Data Base	DB	SOS	SO
Education	ED	Spreadsheets	SS
Emulation	AE	Telecom.	TC
Financial	FI	/// E-Z Pieces	EP
Fortran	FO	Word Proc.	WP
General	GE		

Name	Area	Telephone	Days	Hours	Zone	Subjects
Coville Woodburn	NH	(603) 863-5590	M,Tu,Th,F	7-8pm	Eastern	BB, CT, GE, GR, MI, QU, WP
Ken Johnson	MA	(413) 253-2298	Su-Sa	6-9pm	Eastern	BB, PA, MD, WP, MI
Don Loosli	MI	(313) 626-3848	M-F	9am-5pm	Eastern	GE, WP, SS, DB
Harry T. Hanson, Ph.D.	NJ	(201) 467-0712	M-F	6-9pm	Eastern	GE, PA, BB, CT
Edward N. Gooding, Sr.	VA	(804) 747-8751	Su-Sa	6-9pm	Eastern	CO, SS, PR, MD, CT
Jeff Fritz	WV	(606) 353-9493	M-Sa	8-11pm	Eastern	BB, DB, GE, MI, SS, TC, EP
Al Johnston	FL	(904) 739-1600	M-F	9am-6pm	Eastern	GE
Paul Sanchez	FL	(305) 266-5965	Su-Sa	10am-4pm	Eastern	SS, PR, CT
R.B. Thompson	NC	(919) 787-1703	Su-Sa	10am-10pm	Eastern	BB, DB, GE, SS, WP
J. Donald Glenn	NE	(402) 291-9177	Su-Th	7-10pm	Central	GE
Scott Weddel	NE	(402) 572-7543	Su-Sa	4-10pm	Central	GE, TC
Jim Ferenack	IL	(312) 599-7505	M-F	10am-5pm	Central	GE, EP, DB
Neil Quellhorst	IL	(217) 434-8727	Su-Sa	7-9pm	Central	AL, BB, GR, PA, SO, TC
Ron Maupin	TX	(512) 280-0144	Su-Sa	8am-10pm	Central	AL, CO, CT, EP, MD, PA, QU, SS, TC, WP
Terri Wiles	CO	(303) 850-7472	Su-Sa	10am-6pm	Mountain	PA
William Prince	OR	(503) 254-6465	M-F	9am-4pm	Pacific	GR, TC, Corvus
Karl La Rue	WA	(509) 582-6459	F-Su	6-10pm	Pacific	MD, GE, EP, WP, TC, SS, CP
Pat Holwagner	CA	(415) 433-2323	M-F	10am-6pm	Pacific	GE, SS, WP, CT, DB, SU, AE, EP
M. Kent Hockabout	CA	(415) 865-8579	M-F	9am-10pm	Pacific	DB, GE, GR, MI, MD, QU, SO, SS, TC, WP, AE, EP
Vincent F. Latona	CA	(818) 703-0330	M-F	9am-5pm	Pacific	GE, WP, BB, SS, AE
Wayne Hale	CA	(619) 450-3856	M-F	7-11am	Pacific	BB, GR, CT
Dennis R. Cohen	CA	(818) 956-8559	Su, M-F,	10am-10pm 7-9pm	Pacific	GE, PA, MU, WP, DB, SO
Kelly C. McGrew	WA	(206) 943-8533	Su-M, Th-Sa	7-9pm	Pacific	DB, GR, SS, PR, MD, CT
H. Van der Straeten	Belgium	(015) 205328	Su-Sa	7-10pm	—	BB, CT, DB, GE, PA, PR, SS

Graphically Speaking

melvin a. astrahan, ph.d.

In part I of this series on animation techniques I presented an assembly language subroutine which inverts the state of a single pixel at some X-Y coordinate of the “double hi-res” monochrome screen. Although it is a relatively quick routine, drawing a large object one pixel (or “bit”) at a time severely limits the complexity of an animated object. In this article we will begin to look at ways to animate large and complex objects.

It's a Tough Job

The most obvious way to speed up the process of displaying an object is to draw that object one byte at a time rather than one bit at a time. By placing seven pixels on the screen for each memory operation (remember the seven bit per byte graphics stuff?) a near seven-fold speed enhancement is realized. The problem is in how to smoothly animate objects drawn a byte at a time. . .

First, let's look at how we create a byte-oriented object. As an example, I'll use the ghost (JOB) character from my Sandman game. I decided to design my characters to fit in a rectangular array 14 columns (two bytes) wide by 16 rows high. This requires 32 bytes to store the basic image of the ghost. The basic ghost pattern is illustrated in figure 1. Bits which are “on” are drawn as asterisks (*) for clarity, bits which are “off” are shown as periods (.).

Consider for a moment the code required to *vertically* move the image of the ghost on a blank screen. The ghost must first be drawn at one location on the screen, then erased, and then drawn again at its new location. If we were to draw the entire ghost for each of these operations, it would require a minimum 32 operations to draw, 32 to erase, and 32 to redraw the image for a minimum overhead of 96 operations.

figure 1

	byte 0	byte 1
Row 01:** **.....	
Row 02:	...**** ****...	
Row 03:	..**** ****..	
Row 04:	.**** ****.	
Row 05:	..** ** ..**.	
Row 06:	***** *****.	
Row 07:	***** *****.	
Row 08:	***** *****.	
Row 09:	***** *****.	
Row 10:	.**** ****.	
Row 11:	..**** ****.	
Row 12:	..** ** ..**.	
Row 13:	..**** ****.	
Row 14:	***** *****	
Row 15:	***** *****	
Row 16:	..**... ...**.	

To obtain the smoothest appearing animation, we would like to move the ghost in the smallest vertical increment possible, which is one screen row or “raster.” This means that in the process of redrawing the ghost only one raster higher or lower on the screen, we are rewriting to 30 of the 32 memory locations we just erased. This is rather inefficient to say the least. One approach to speeding up vertical movement is to add one extra row of blank or “off” pixels just above the ghost, and another just below it as illustrated in figure 2.

This increases the number of bytes which must be drawn from 32 to 36 per ghost, but allows the ghost to erase himself as he moves vertically one raster at a time by eliminating the need for an explicit erase cycle. The number of operations for a draw-erase-redraw operation is therefore reduced from 96 to 72 for a 25% savings in overhead.

Now let us turn our attention to horizontal movement. This is a “bit” trickier (excuse the pun). We are faced with an additional problem for horizontal movement. If we move the ghost one full byte to the left or right in screen memory, we can draw-erase-redraw in a manner similar to that originally suggested above for vertical movement, but motion by an increment of seven pixels at a time will appear rather jerky.

To bit shift the image directly in graphics memory one pixel at a time using LSR-ROR-ROR or ASL-ROL-ROL commands would efficiently permit single pixel movement. About 48 (16 X 3) operations would be necessary since rows 00 and 17 are not required for horizontal movement. Unfortunately, due to the

figure 2

	byte 0	byte 1	
Row 00:	<-- blank row added here
Row 01:** **.....		
Row 02:	...**** ****...		
Row 03:	..**** ****..		
Row 04:	.**** ****.		
Row 05:	..** ** ..**.		
Row 06:	***** *****.		
Row 07:	***** *****.		
Row 08:	***** *****.		
Row 09:	***** *****.		
Row 10:	.**** ****.		
Row 11:	..**** ****.		
Row 12:	..** ** ..**.		
Row 13:	..**** ****.		
Row 14:	***** *****		
Row 15:	***** *****		
Row 16:	..**... ...**.		
Row 17:	<-- blank row added here

extended memory environment of the Apple III, indirect addressing mode instructions are difficult to use with graphics bank memory, since they are not allowed by the 6502 in this environment.

Another limitation of these techniques is that they only permit animation of an object in the sense that the whole object may be moved "as-is." What if we want to combine one pixel movement of an object with more complex animation, such as arm and leg movement, the opening and closing of a mouth, or the blinking of an eye?

figure 3
byte 0 byte 1 byte 2

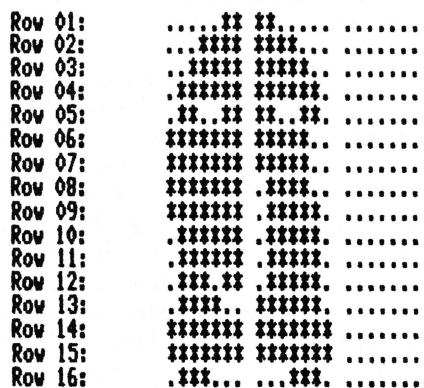

A more general solution to complex animation and horizontal movement is to draw the ghost on a matrix three bytes wide as illustrated in figure 3. Now, since 48 rather than 32 operations are required to draw a ghost, the time required to draw it increases

proportionally, but results in a more general and powerful animation technique.

As our ghost moves to the right (for example) one pixel at a time, it is evident that there are seven possible horizontally bit-shifted configurations. Once the ghost has moved seven pixels to the right, the ghost will once again be exactly aligned within two byte boundaries. Rather than bit-shift the image in graphics memory or use the draw-erase-redraw technique, we can pre-calculate the seven possible bit-shifted ghosts. This eliminates the need for an erase cycle, and allows horizontal movement of between one and seven pixels at no additional overhead. Moving two pixels at a time to the right, for instance, would double the number of LSR-ROR-ROR operations.

Furthermore, to provide the illusion of more complex animation, each precalculated bit-shifted image can also include additional sub-animation effects within the 48 byte matrix at no extra cost. A simple lookup table can tell us which image to use at each X coordinate on the screen. Precalculated vertically animated images can also be used with a Y coordinate lookup table. (Note how Sandman gobbles up the dots in the game.)

One- and two-bit right shifts of the ghost with additional sub-animation of a blinking right eye are illustrated in figure 4.

This is a classic example of trading memory for execution speed and

power by pre-calculating as much as possible and using extensive lookup tables. In my next article, we will look at how to prepare the actual data base and lookup tables for the ghost, and an assembly language program to animate him.



(Cont'd from page 29)

From BASIC, you must INVOKE the module CATALYST.UTIL and then PERFORM BYE when you are ready to exit. This little test program should give you the idea.

```

10 INVOKE .PROFILE/CATALYST/CATALYST.UTIL
20 PRINT "Do you want to quit? (Y/N)"
30 GET Answer$
40 IF Answer$ = "Y" or Answer$ = "y" then
   PERFORM BYE
50 PRINT "Thanks for staying with us"
60 GOTO 20
70 END

```

Type in this program and run it. You will go immediately back to the Catalyst menu when you answer "Y" or "y".

In Pascal, you need to add an external PROCEDURE called BYE. When you wish to exit, call the BYE procedure. Once all your source code is complete, you must compile and then link the procedure found in the library .PROFILE/CATALYST/CATALYST.UTIL. The following Pascal program can be used to test the principle.

```

PROGRAM Good_bye;
VAR
  answer : CHAR;
PROCEDURE Bye; EXTERNAL;
BEGIN
  Writeln ('Do you want to quit? (Y/N)');
  Read (answer);
  IF (answer = 'Y') OR (answer = 'y')
  THEN
    Bye
  ELSE
    Writeln ('Thanks for staying with us')
END.

```

Type in the above program, compile and link it, then execute it. Like the BASIC program, an answer of "Y" or "y" will bring you immediately to the Catalyst menu.

Catalyst is an extremely useful tool for the user of the Apple III and these additional features should enhance your use of this program.



figure 4

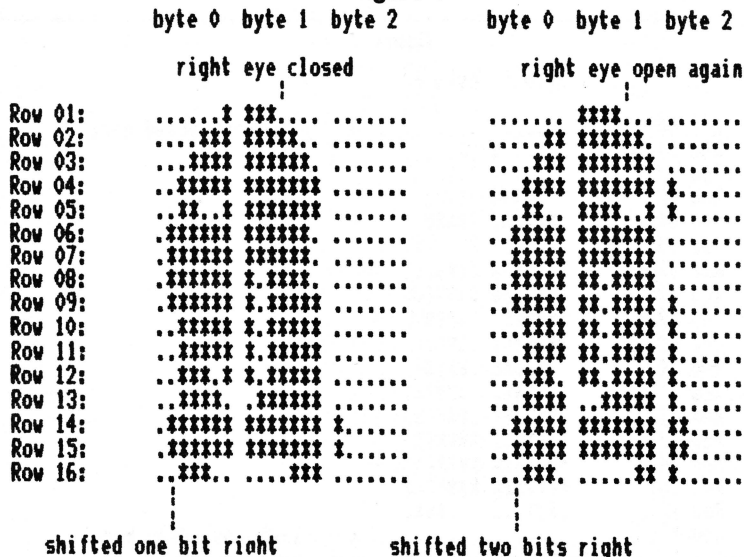

Close Out! on all Micro Sci Disk Drives

Lowest prices anywhere!



A3 - 140K
was \$299.00 now only \$225.00

A143 - 560K
was \$399.00 now only \$325.00
plus \$6.50
shipping/handling per drive



Price Reduction Game Card ///

was \$59.95 now only \$49.95
plus \$2.00 shipping/handling

**Save \$\$\$ now
while supplies last**

Quantities Limited
Call for availability



ON THREE
P.O. BOX 3825
VENTURA, CA 93006

TOLL FREE
(800) 443-8877

IN CALIFORNIA
(805) 644-3514

Mastercard, Visa, American Express*
*3% Surcharge on American Express

Smart users select **Selector ///**

The smart Program Switching utility
from ON THREE

- Switch to Selector /// now
 - Ideal for UniDisk or hard disk systems
 - Compatible with more than two dozen major Apple /// applications
 - AppleWriter ///
 - Business Basic
 - Habu Merge
 - VisiCalc
 - /// E-Z Pieces
- ...and more

\$99 plus \$7 s/h

Selector /// is a state-of-the art program switcher.

A program switcher is a utility that functions as your computerized personal secretary. Its purpose is to make instantly available to you, without rebooting, a wide range of applications programs stored on your hard disk or high capacity floppy (such as UniDisk). Programs such as AppleWriter ///, Quick File /// and more than two dozen others.

Each time you require a different application, just tell your personal secretary, *Selector ///*, with a couple of keystrokes, and it will be there in a couple of seconds. No need to find your way through sub-directories or paw through a stack of floppies.

When you start your system up in the morning, just boot *Selector ///* and that's it for the day. Smart users are switching to and with *Selector ///* now.

Selector /// works with all of these programs:

- | | | |
|----------------------|--------------------------------|----------------------|
| ✓ Access /// | ✓ Business Basic | ✓ Multiplan |
| ✓ Access 3270 | ✓ Business Graphics | ✓ Nexus |
| ✓ Advanced VisiCalc | ✓ Cobol | ✓ PFS: File * |
| ✓ Apple II Emulation | ✓ Draw ON /// | ✓ PFS: Graph * |
| ✓ AppleFile /// | ✓ Easyterm | ✓ PFS: Report * |
| ✓ Apple Speller /// | ✓ Graph'n Calc | ✓ Quick File /// |
| ✓ Apple /// Pascal | ✓ Habu Merge | ✓ Script /// |
| ✓ AppleWriter /// | ✓ Keystroke Data Base * | ✓ Senior Analyst /// |
| ✓ Backup /// | ✓ Keystroke Report Generator * | ✓ VisiCalc /// |
| ✓ BPI | ✓ Lazarus /// | ✓ /// E-Z Pieces |

and Word Juggler tool! (with a public domain disk from your local user group. Contact them for details.)

*Indicates boot disk required in internal drive.

BULK RATE
U. S. POSTAGE
PAID
Permit No. 90
Ventura, CA

ON THREE Presents . . .

Draw ON ///

The most versatile Apple /// graphics tool ever designed!

- Use Draw ON /// directly with Apple ///e mouse and interface, joystick, keyboard, or Apple Graphics Tablet (Graphics Tablet version \$50 additional)
 - Draw ON /// can spruce up dull graphs or by creating fancy borders and textured images
 - Draw ON /// comes complete with easy to follow menus, a durable spiral-bound instruction manual and tutorial, keypad overlay, and unprotected diskettes which will install on Selector /// or Catalyst
 - Draw ON /// is compatible with all monochrome monitors as well as NTSC (standard) and RGB (hi-res) color monitors
- Multiple help screens
 - User-adjustable grids
 - Zoom in for detailed work
 - Rubber-banding of lines

\$179 . . . plus \$5 shipping and handling

What? A computer graphics program that is powerful and easy to use, has the resources of a complete graphics art studio, creates professional-quality charts and diagrams, complex illustrations and original artwork, letterheads, slides and tables for presentation? Don't you believe it! . . . unless you're talking about Draw ON ///™, from ON THREE!

Draw ON /// transforms your Apple /// into a drafting table, easel and sketch pad, all rolled into one, like MacPaint with color. Computer Aided Design (CAD) applications such as circuit layouts and flowcharts are childs play for Draw ON ///.

Draw ON /// comes with a wide selection of text fonts and objects which can be supplemented with those of your own design. Mix and match with drawings and charts, using Draw ON ///'s powerful cut and paste facility. You can use Draw ON ///'s many fonts to label your own drawings as well as those in other applications, and you can pick up objects, expand, shrink, rotate, invert, and texture.

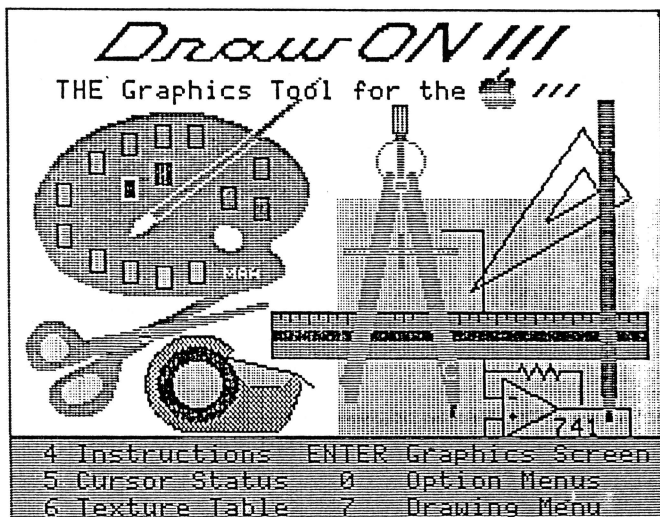

Draw ON /// requires 256K minimum memory

Look!

You can print Draw ON /// screens with all of these popular printers:

- Apple DMP
- Epson FX, MX, RX series
- ImageWriter
- ProWriter

plus, with a PKASO/ PKASO-U interface:

- Centronics
 - IDS Prism, Color Prism*
 - NEC
 - Okidata
 - . . . and others
- *required to print color drawings

Specify printer and interface when ordering